

NORTH SHORE EQUITABLE BUILDING

PITTSBURGH, PA

STEPHAN NORTROP - STRUCTURAL OPTION



FINAL THESIS REPORT

FACULTY CONSULTANT: DR LINDA HANAGAN

APRIL 11, 2011

NORTH SHORE EQUITABLE BUILDING

225 North Shore Drive, Pittsburgh, PA



Stephan Northrop - Structural Option

DESIGN TEAM

- Owner: Continental Real-Estate
- General Contractor: Continental Building Systems
- Architect: Strada Architecture LLC
- Civil: GAI Consultants
- Structural: Michael Baker Corporation
- Mechanical: Ruthrauff Inc
Burt Hill Kosar Rittelman
- Electrical: Starr Engineering
- Plumbing: Scalise Industries

MEP SYSTEMS

- VAV system with 30,000 CFM air intake on the roof meeting the entire building load
- 277 volt fan powered boxes on levels 2 - 5
- Mechanical rooms above the lobby on levels 2 - 5
- 277/480 volt 3 phase 4 wire power system
- Recessed metal halide lamps and wall mounted fluorescent lights providing majority of lighting

CONSTRUCTION

- Design/Build delivery method
- 14 month construction period
- \$70 million total project cost

ARCHITECTURAL FEATURES

- 180,000 Sq Ft, 6 stories above grade, 1 parking sublevel
- The lower half of the facade is cast stone masonry units and the upper half consists of composite metal panel
- Foundation is designed to accommodate a light rail transit line passing under the building
- Aesthetic features include two towers and a turret located at 3 of the building's 4 corners
- The building offers a fitness center and a North Shore riverfront park with views of the Pittsburgh skyline



STRUCTURAL

Foundation: 18" augercast piles and steel piles

Gravity System: Steel beams and girders spanning 30 to 40 Ft with W14 columns on every level

Lateral System: braced frames and moment frames surrounding core of building on all levels

Floor System: 5 1/2" composite floor slab with a 2" metal floor deck

Roof System: 1/2" galvanized roof deck supported by K series joists and steel girders

<http://www.engr.psu.edu/ae/thesis/portfolios/2011/smn5025/index.html>

ACKNOWLEDGEMENTS

The author would like to acknowledge the following individuals for their invaluable contributions to this thesis project. Without your support, generosity, assistance and advice, this thesis would not have been possible. Thank you.

Members of the primary project team

Mike Hudec	Continental Real Estate
Robert Modany	Continental Real Estate
Dina Snider	Strada Architects
Ken Ash	Michael Baker Corporation
Louis Middleman	Michael Baker Corporation

The Pennsylvania State University;

Dr. Linda Hanagan

Prof. M. Kevin Parfitt

Prof. Robert Holland

Ryan Solnosky, Shaun Kreidel and Dr. Andres Lepage for their assistance

The entire AE faculty and staff

My gratitude also goes out to my family and friends whose constant support and encouragement have helped me complete this thesis and my education at the Pennsylvania State University.

TABLE OF CONTENTS

Abstract	
Acknowledgements	
Executive Summary	5
1. Introduction	6
2. Existing Structural System	7
▪ Foundation	7
▪ General Floor Framing	8
▪ Turret Framing	9
▪ Roof Framing	10
▪ Lateral Resisting System	11
3. Problem Statement	13
4. Proposed Solution	14
5. Structural Depth Study	15
▪ Materials Used	15
▪ Applicable Codes	16
▪ Proposed Gravity System	17
▪ Proposed Lateral System	28
▪ Computer Model Analysis	36
▪ Foundation Assessment	41
6. Breadth 1: Cost & Schedule	43
7. Breadth 2: Acoustic Analysis	46
8. Conclusions & Recommendations	49
9. Appendices	50
• Appendix A: Floor System Gravity Design	50
• Appendix B: Column Gravity Design	70
• Appendix C: Wind Load Calculations	81
• Appendix D: Seismic Calculations	88
• Appendix E: Computer Model Analysis Outputs	93
• Appendix F: Foundation & Overturning Checks	98
• Appendix G: Cost & Schedule Analysis	100
• Appendix H: Acoustic Analysis	103

EXECUTIVE SUMMARY

The North Shore Equitable building is a 6 story, 180,000 square foot low rise commercial office building located on Pittsburgh's North Shore. The existing structure consists of composite steel beams and girders oriented in a rectangular grid pattern. The lateral system consists of braced frames spanning in the transverse direction and steel moment frames running in the longitudinal direction. The foundation consists of a combination of auger cast piles and steel H piles.

Since the existing composite steel design is such an excellent design choice for this particular building, it is hard to find design aspects that leave room for improvement. One such design aspect, however is the light rail transit line extension that is currently being built below the existing foundation of the building and could potentially introduce unwanted noise and vibrations into the building work space. Therefore, for the purpose of this thesis, the building was redesigned as a one way concrete pan joist and beam system. The goal of this redesign is to improve the building's noise control while maintaining the current grid layout.

The redesigned gravity system of this building consists of pan joists running in both transverse and longitudinal directions to reduce large tributary areas found in exterior bays. A reduction in floor system thickness reduced the height of each story by 10 inches, resulting in a new building height of 81' 9" (a reduction of 5' 4"). The redesigned lateral system of this building consists of concrete moment frames supplemented with 24" x 48" rectangular and L-shaped columns along exterior grid lines to increase stiffness. Framing of the stairwells and elevator shafts using concrete shear walls was avoided due to unwanted torsion that would be introduced into the design. Due to an increase in building weight, the foundation of the building was evaluated and the auger cast pile caps were redesigned to support an increased axial load.

In order to most effectively compare the new and existing structural system, a cost and schedule analysis was performed as well. The results of this analysis showed that the building cost will decrease slightly due in part to the decrease building height but the project schedule length increased due to the use of concrete rather than steel.

Finally, an acoustic analysis was performed to compare the new and existing systems from a noise reduction standpoint. This analysis showed that noise control was improved in the redesigned structure in the foundation, the ground level floor systems and in the roof systems.

The purpose of this thesis was to improve noise control while maintaining the current building layout. The results of this report show that a one way concrete pan joist and beam system will improve noise control, decrease building cost, and maintain an adequate gravity and lateral system to support all applied loads.

1. INTRODUCTION

The North Shore Equitable Building is a 6 story, 180,000 square foot low rise commercial office building located on Pittsburgh's North Shore. Completed in 2004, this building is part of the North Shore development project between Heinz Field and PNC Park. Of the building's 180,000 square foot area, 150,000 square feet consists of office space on floors 2 to 5 and the remaining 30,000 square feet is retail space on the ground level. In addition to the 6 above grade levels, one sublevel of parking is also provided, which accommodates 80 vehicles. The North Shore Equitable Building offers its tenants amenities such as an employee fitness center, a test kitchen for product development and the North Shore Riverfront Park which offers access to riverside trails and beautiful views of the Pittsburgh skyline across the Allegheny River.

Among the Equitable building's notable architectural features are what is referred to as a turret, located at the southwest corner of the building and two towers located at the northwest and southeast corners of the building respectively. The majority of the building's façade consists of cast stone masonry units up to the third level and a combination of composite metal paneling and face brick from the third level up to the roof level. Two skylights can be found on the roof as well with the architectural designs including a location for a proposed third skylight which was never built.



Figure 1-1: View of the North Shore Equitable building from Mazeroski Way

2. EXISTING STRUCTURAL SYSTEM

The structural system of the North Shore Equitable Building consists of composite steel beams and girders to resist gravity loads and a combination of braced frames and moment frames to resist lateral loads. These components of the building's structural design, along with all other structural design components, will be described in further detail below.

Foundation

The foundation consists of a 5 ½" slab on grade supported by concrete grade beams and a combination of 18" auger cast piles and steel H-piles. Reinforced concrete retaining walls in the parking garage extend from the top of the grade beams to the first floor framing. These walls are restrained at the top by the first floor framing.

The piles for the Equitable Building pose a unique set of design requirements. The Allegheny Port Authority is currently extending their light rail transit system under the Allegheny River to Pittsburgh's North Shore. This extension consists of two parallel tunnels which are designed to pass directly below the Equitable Building as seen in Figure 2-1. As a result, the foundation is designed as a combination of two types of foundations; driven Steel H-piles (Figure 2-2 on the right) to withstand pressures and settlement resulting from tunneling under the building and 18" auger cast piles (Figure 2-2 on the left) for the remainder of the foundation.

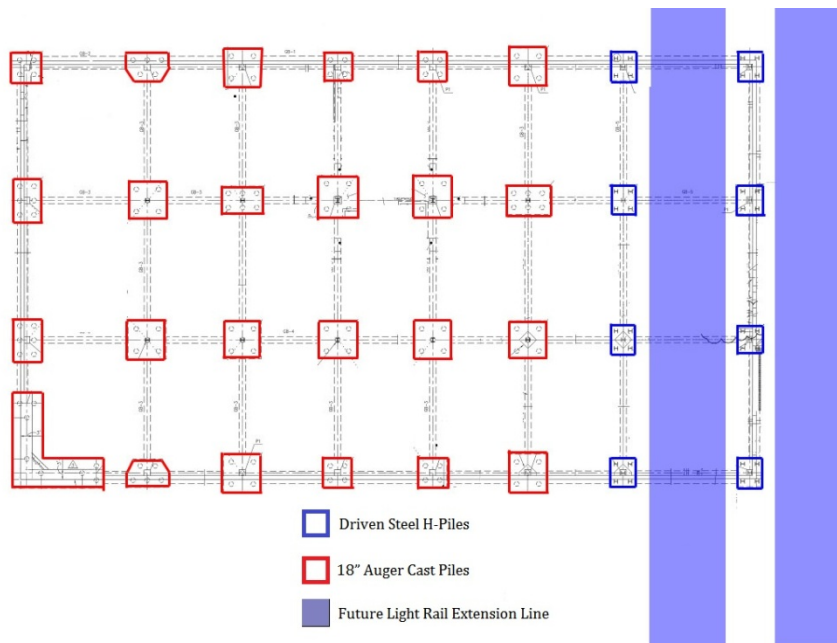

Figure 2-1: Foundation plan with future transit line extension

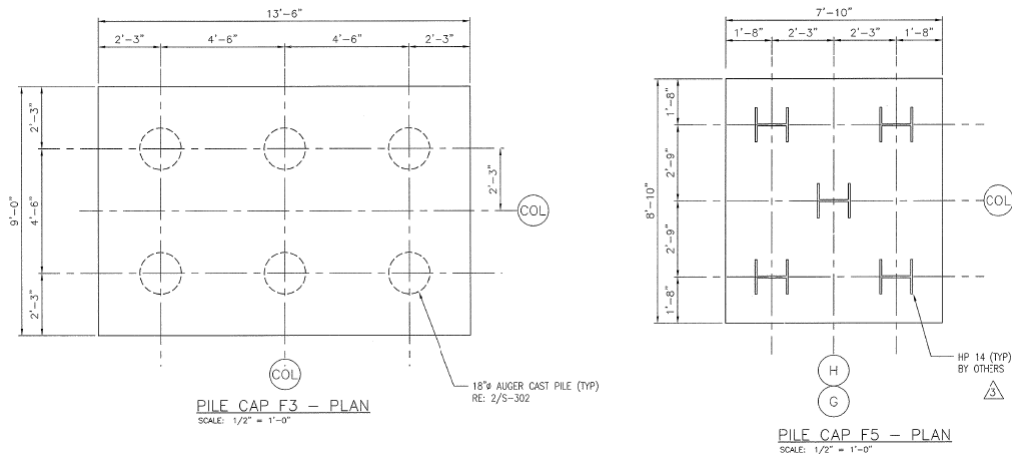

Figure 2-2: Typical 18" auger cast pile cap (left) and typical steel H pile cap (right)

General Floor Framing

Due to the equitable building's rectangular shape, the framing follows a simple grid pattern (128' wide by 228' long). Framing consists of a lightweight concrete slab supported by steel beams, girders and columns. The slab has a total depth of 5 1/2" consisting of 3 1/2" lightweight concrete over a 2" 18 gage composite galvanized metal floor deck. The floor is supported by steel beams, typically W18x40's in exterior bays and W21x44's in interior bays, framing into girders ranging in size from W24x62 to W30x116. There are 7 bays on each level (approximately 30' x 42' or 40' x 42' for exterior bays and 30' x 44' or 40' x 44' for interior bays). The beams span 44' in the interior bays and 42' in the exterior bays and are spaced no more than 10' apart. The girders typically span either 30 or 40 feet. Shear studs (4 1/2" length, 3/4" diameter) are used to create composite action between the deck and the steel beams. Figure 2-4 on the following page shows the typical floor plan for the existing structural system.

Columns for the Equitable Building are all W14 wide flange columns ranging in weight from W14x311 on the first level to W14x48 extending up to the roof level. Columns are spliced at two locations along the vertical length of each column line at 4' above the floor level indicated. A typical column splice detail is shown to the right in Figure 2-3.

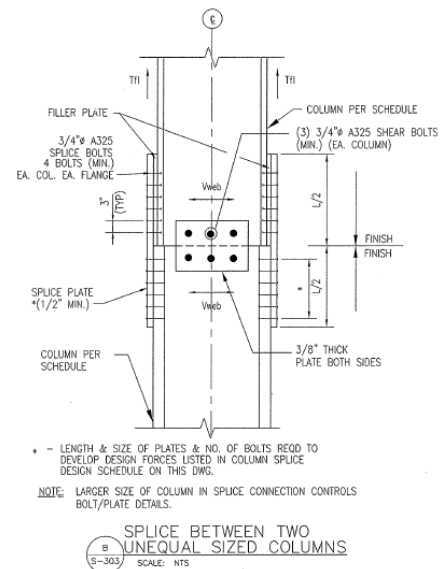

Figure 2-3: Typical column splice detail

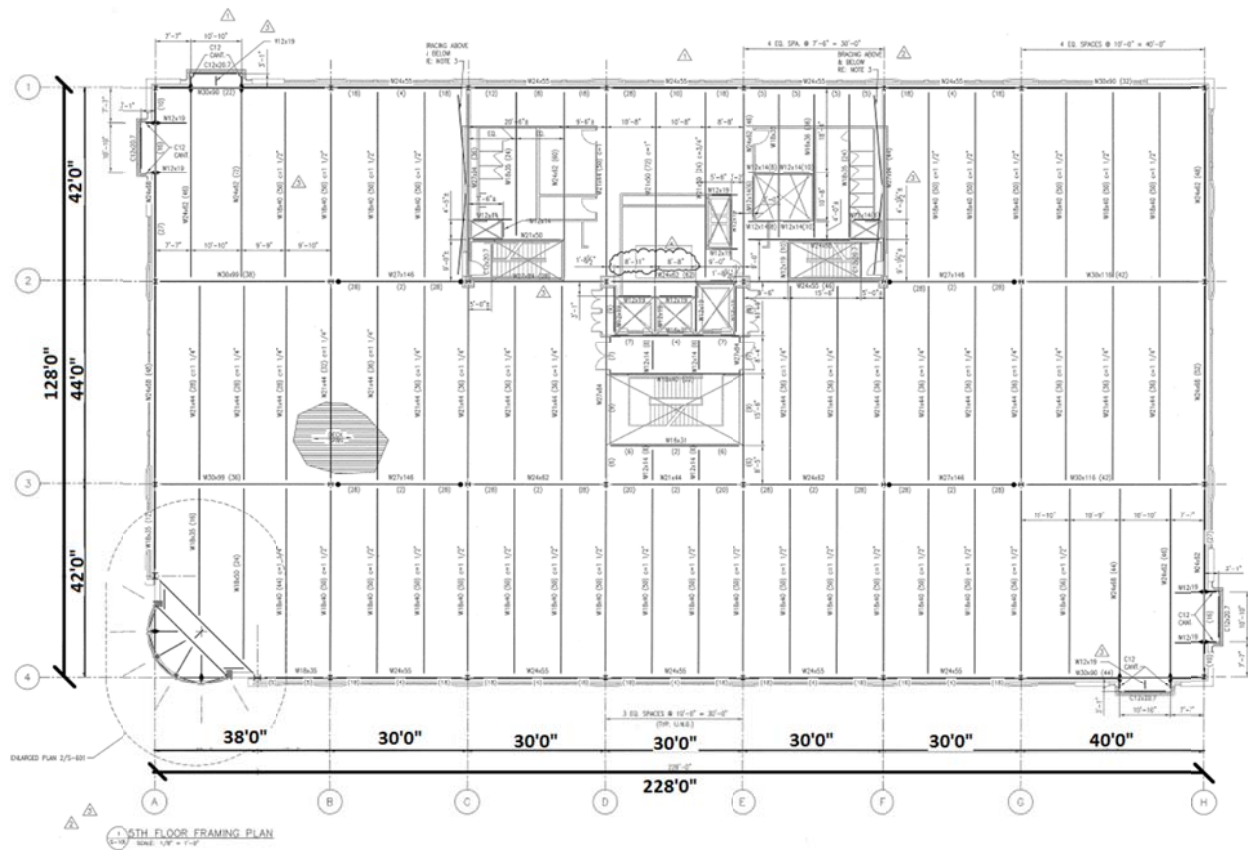
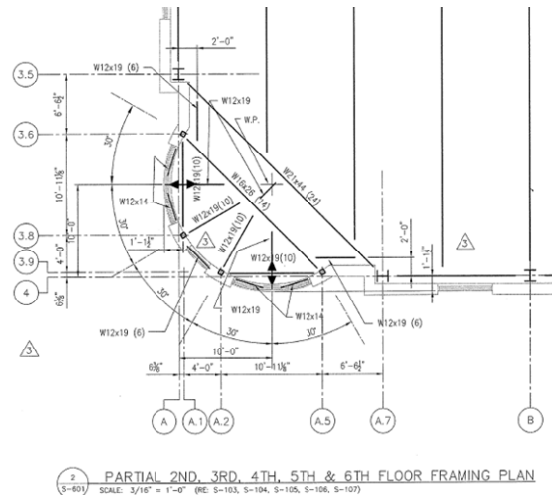

Figure 2-4: Typical floor framing plan

Turret Framing Plan

For the turret at the southwest corner of the building, members of varying sizes are used as seen to the right in Figure 2-5. The columns for the turret are HSS columns ranging in size from HSS 6x6x 1/2 (on the first level) to HSS 6x6x 3/16 extending up to the roof level. These HSS columns are spliced at three locations along the column line.



2 PARTIAL 2ND, 3RD, 4TH, 5TH & 6TH FLOOR FRAMING PLAN
3-601 SCALE: 3/16" = 1'-0" (REF. S-103, S-104, S-105, S-106, S-107)

Figure 2-5: Turret framing plan

Roof Framing Plan

The roof framing system, like the floor framing system, is laid out in a simple rectangular grid. It consists of a 1 1/2" 20 gage type B galvanized roof deck supported by open-web K-series joists (Figure 2-6) which frame into wide flange girders. The roof deck spans longitudinally which is perpendicular to the joist span direction. The K-series joists are generally either 28" or 30" deep and span either 44' (in interior bays) or 42' (in exterior bays). These joists are spaced no further apart than 5' typically.

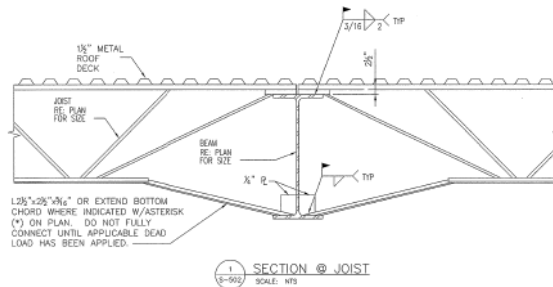

Figure 2-6: Section at joist

The girders in the roof plan vary greatly in both size and span length. Girders carrying the typical roof load vary in size from W18x35's to W30x116's (spanning anywhere from 16' to 44'). The roof girders above the core of the building supporting mechanical equipment are mainly W12x19's and W24's with a few W14's and W18's used as well. 10" and 30" deep KCS-Type open-web K-series joists are also used to help support this equipment.

The framing of the tower roofs consists of C10x20's, W10x22's and L2 1/2 x 2 1/2 x 1/4 horizontal bridging, as seen in Figure 2-7. The framing of the turret roof consists of curved C6x13 members and wide flange members of varying lengths as seen in Figure 2-8.

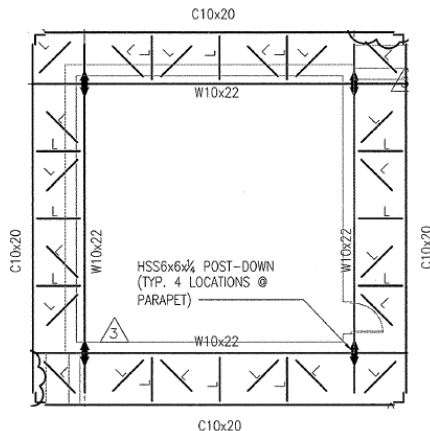

Figure 2-7: Tower roof framing plan

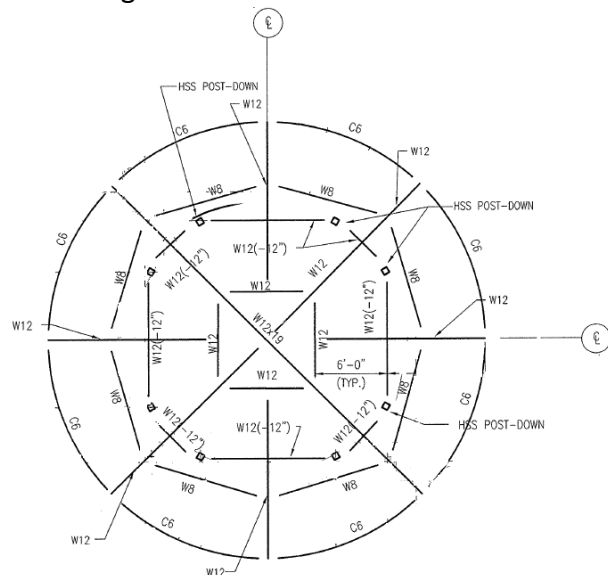

Figure 2-8: Turret roof framing plan

Lateral Resisting System

Lateral stability in the North Shore Equitable Building is achieved through the use of a combination of braced frames and moment frames. Braced frames run in the transverse direction and moment frames run in the longitudinal direction as seen in Figures 2-9 and 2-10 below. The floor and roof decks, which act as horizontal diaphragms, transfer lateral forces to the frames. Elevation views of these frames can be seen in Figures 2-11 and 2-12. The connections in the moment frames are semi rigid connections. Details of a typical braced frame connection and a moment frame connection are shown in Figures 2-13 and 2-14 respectively.

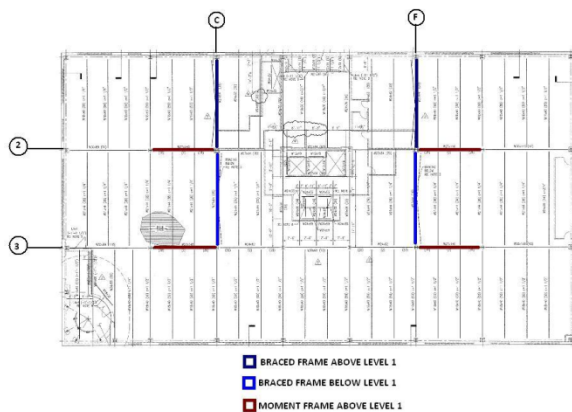

Figure 2-9: Lateral Resisting elements at level 1

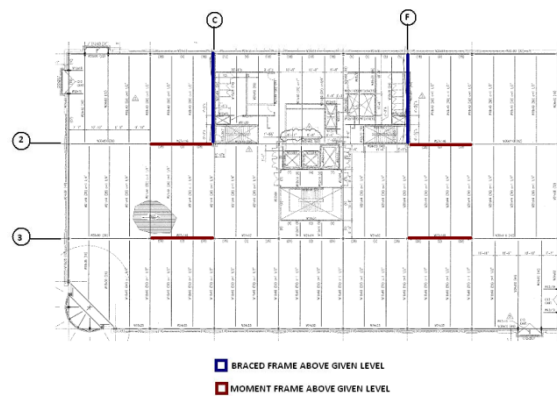

Figure 2-10: Lateral Resisting elements at levels 2-6

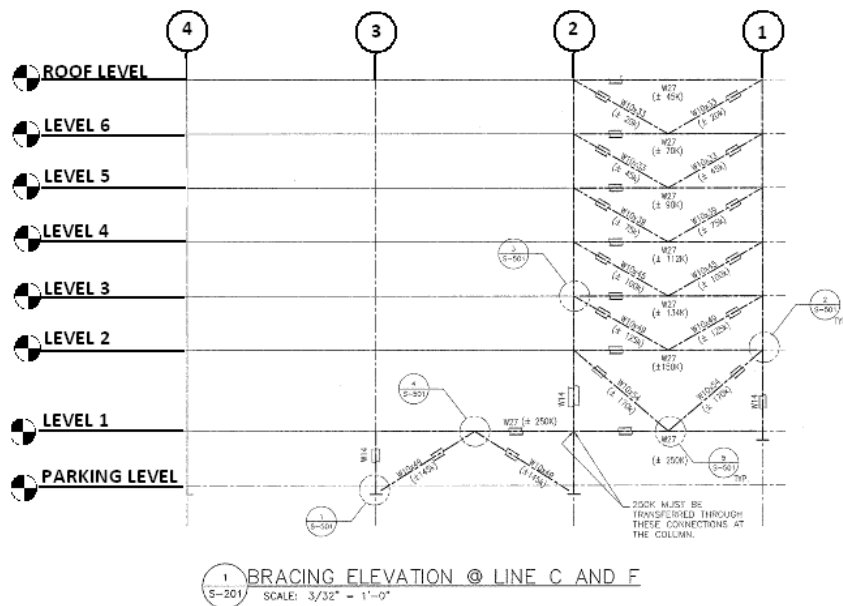
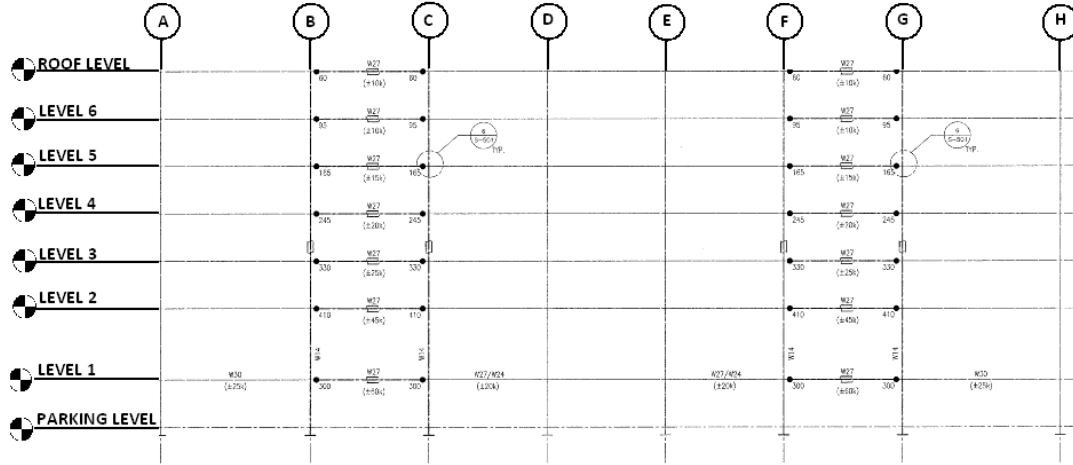
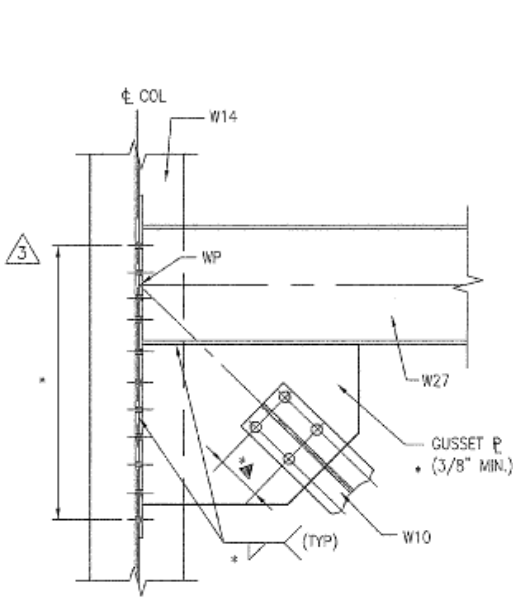

Figure 2-11: Braced frame elevation



2 MOMENT FRAME ELEVATION @ LINE 2 AND 3
 S-201 SCALE: 3/32" = 1'-0"

Figure 2-12: Moment frame



3 BRACING @ COLUMN (INTO WEB)
 S-501 SCALE: NTS

Figure 2-13: Braced frame connection

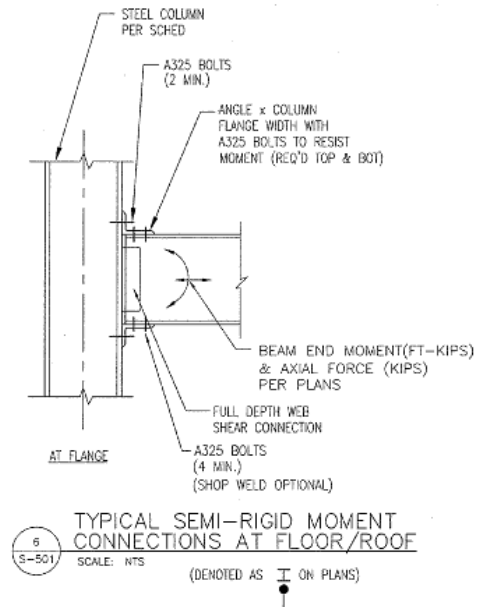

5 TYPICAL SEMI-RIGID MOMENT CONNECTIONS AT FLOOR/ROOF
 S-501 SCALE: NTS (DENOTED AS  ON PLANS)

Figure 2-14: Moment frame connection

3. PROBLEM STATEMENT

As mentioned in the structural systems overview above, the existing design of the North Shore Equitable Building is a lightweight composite slab supported by steel beams, girders and columns to resist gravity loads. Lateral loads are resisted by a combination of braced frames running in the transverse direction and moment frames running in the longitudinal direction.

When this building was originally designed, the engineers were faced with the task of designing the structure to accommodate a future light rail transit line extension that will pass below the building. Because of this, large bay sizes were a requirement so that the foundation would not interfere with the transit line. Larger bay sizes were also emphasized in order to provide more flexibility for future open office space. Incorporating the transit line into this design makes vibration and noise reduction key design issues.

Although the existing composite steel system is an appropriate design choice for this building, an alternate structural system will be investigated for the purpose of this thesis in order to put greater emphasis on improving noise reduction with regards to the light rail transit line passing below the building.

Project Goal: The goal of this thesis is to redesign the North Shore Equitable Building with an alternate structural system in an attempt to improve noise control and reduce vibrations while also attempting to maintain the existing grid layout.

4. PROPOSED SOLUTION

From Tech Reports 1 through 3, it was determined that both the existing composite steel frame system and a one way joist and beam system are viable options for the design of the North Shore Equitable building.

A composite steel system was chosen by the engineers for the original design for several reasons. Steel framing systems are relatively easy to design (compared to concrete systems), quickly and easily erected, and provide a relatively light and open floor plan at a reasonable cost. There are some disadvantages however, such as reduced noise control which is one of the focus areas of this thesis. Improved vibration damping is also an advantage of redesigning the structure using concrete.

The proposed solution for this thesis is to redesign the building using a one way concrete joist and beam system. A preliminary analysis of this system in Tech Report 2 yielded a potential floor system thickness of 24.5" consisting of a 4.5" slab and 20" deep joists (as shown in figure 5-1 below). Girders were also estimated with a width of 40" and a depth of 24.5". This alternate structural system has inherent vibration resistance and will potentially decrease vibrations and noise transmission throughout the building. Using a one way joist and beam system will also allow for long spans in the column grid to be maintained. With this new design, the foundation may need to be redesigned to accommodate higher building loads. The lateral system will need to be redesigned as well. This redesigned system will consist of concrete moment frames supplemented with thick columns acting as shear walls to increase stiffness and reduce torsion. A cost and construction analysis will be necessary since the main material used will change from steel to concrete. In addition to looking at the foundation, lateral system and construction, an acoustic analysis will be performed to research the effect a joist and beam system has on noise transmission as compared to the existing composite steel system.

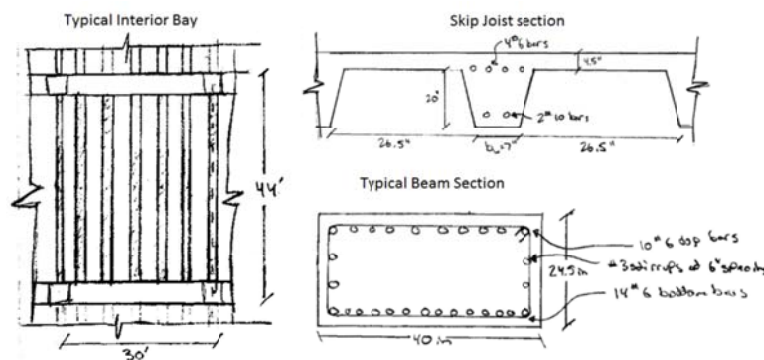

Figure 4 - 1: One way joist and beam system details

5. STRUCTURAL DEPTH STUDY

This chapter documents the procedure used to redesign the structural system of the North Shore Equitable building to support gravity loads. As mentioned previously, a one way concrete pan joist and beam system will be designed in place of the existing composite steel system.

Materials Used

As mentioned previously, the predominant structural material has been changed from steel to concrete in the new design. As with the existing design, standard material strengths are used throughout the building. All concrete members and floor slabs, along with footings and grade beams consist of normal weight concrete. Floor slabs in the redesigned structure are now 150 pcf normal weight concrete as compared to 110 pcf lightweight concrete used in the existing design. The stairwells and elevator shafts, which were support by A992 steel members, are now supported by masonry shear walls. Structural materials used in the redesigned system are shown in the tables below.

TABLE 5.1 - Concrete Materials Schedule

Structural Element	Weight (pcf)	Strength (f'c)
Footings	150	4000
Drilled Piers	150	4000
Grade Beams	150	4000
Slab On Grade	150	4000
Elevated Floor Slabs	150	4000
Auger Cast Piles	150	4000
Girders & Columns	150	4000

TABLE 5.2 - Masonry Materials Schedule

Structural Element	Compressive Strength
Concrete Masonry	1500 PSI

TABLE 5.3 - Steel Materials Schedule

Structural Element	Yield Strength (ksi)	ASTM Designation
Connections, Plates And All	36	A36
Anchor Rods	36	A36
Light Gage Metal Studs	50	A653
Structural Steel Bolts	92	A325
Steel Reinforcing	60	A615

Applicable Codes

Since the North Shore Equitable building was designed and built between 2003 and 2004, the codes used by the designers are a couple editions older than the codes used for this report. In addition the use of ASCE 7-05 in this report, the natural frequency of the building was approximated using ASCE 7-10 chapter 26. This was done due to the fact that ASCE 7-05 appears to offer no method of estimating the natural frequency. The codes used by the designers and in this report are given below.

Codes Used In the Original Design

- The BOCA National Building Code, 1999
- City of Pittsburgh Amendments to The Boca National Building Code
- ASCE 7-95, Minimum Design Loads for Buildings
- ACI 301, Specifications for Structural Concrete for Buildings
- ACI 318-95, Building Code Requirements for Reinforced Concrete
- ACI 530, Building Code Requirements for Masonry Structures
- AISC/ASD-89, Manual of Steel Construction, 9th Edition
- AISC/LRFD-2001, Manual of Steel Construction, 3rd Edition
- SJI-41st Edition, Standard Specifications and Load Tables for Steel Joists and Joist Girders

Codes Used In Tech Reports and Final Report

- ASCE 7-05, Minimum Design Loads for Buildings
- ASCE 7-10, Minimum Design Loads for Buildings (Chapter 26.9)
- AISC Manual of Steel Construction, 13th Edition
- ACI 318-08, Building Code Requirements for Reinforced Concrete

Proposed Gravity System

Gravity Design Loads

For the design of this building, the structural engineers at Michael Baker chose to conservatively take the live load as 100 psf rather than the 50 psf recommended by ASCE 7-05. Having worked at Michael Baker as an intern this past summer, it is my understanding that the structural engineers use 100 psf live loads as a general rule of thumb when designing composite steel buildings. For the redesigned structure in this final report, an 80 psf live load is used rather than the ASCE prescribed 50 psf. This was done in an attempt to be conservative but also to try to avoid overdesigning the alternate system.

TABLE 5.4 - Live Loads

Load Type	As Designed (psf)	Per ASCE 7-05 (psf)	Redesign (psf)
Floor Live Loads			
Office	100	50	80
Corridors	100	100 (first level) 80 (upper levels)	100 (first level) 80 (upper levels)
Mechanical	150	(not provided)	150
Stairs	100	100	100
Retail	100	100	100
Garage Live Load	50	40	40
Roof Live Load	20 (min)	20	20

TABLE 5.5 - Dead Loads

Load Type	As Designed (psf)	Redesign (psf)
Superstructure Weight	5	79.58
Roofing, Ceiling, Misc.	8	8
Collateral Load (MEP)	7	7
Total Roof Dead Load	20	94.58
Concrete Floor Slab	45 (LW composite)	56.25 (NW)
Steel/Joist Framing	10	29.16
Ceiling, Misc.	5	5
MEP	5	5
Total Floor Dead Load	65	95.41
6" Metal Studs + Insul + GWB	10	10
4" Brick	40	40
Total Exterior Wall Load	50	50
Stairs	30	30
Stair Landings	40	40

Alternate Design Considerations

Of the three alternate systems investigated in Tech report 2, the one way concrete joist and beam system was chosen to be investigated further for a number of reasons. Advantages to the joist and beam system include a reduction in floor depth, the potential to maintain or decrease construction costs and an improvement in vibration damping. Its ability to span long distances is also an important advantage considering the design goal of maintaining the existing column grid.

The hollow core plank system was found to have several disadvantages to it including an increase in both weight and floor depth. The need for both concrete formwork and steel fireproofing, along with deeper beams would increase construction costs.

A post-tensioned slab would normally be an attractive design offer in a situation that calls for a concrete structure. In this case however, it was determined in Tech report 2 that a post-tensioned flat slab system (with or without drop panels) would not be able to span the 44' x 38' end bays without exceeding the allowable compression stress limit. Due to the need to maintain the existing grid layout, this made a post-tensioned system a difficult design option. For the reasons given above, the decision was made to redesign the structure of the North Shore Equitable building using a one way concrete joist and beam system.

Design Approach & Iterations

There were several phases in the design process of the one way concrete pan joist and beam system. To begin the design, a simple one way system was estimated using David Fanella's *Concrete Floor Systems: Guide to Estimating and Economizing*. All spans and bay sizes were kept consistent with the existing design. This resulted in a floor plan like the one shown in Figure 5-1 below.

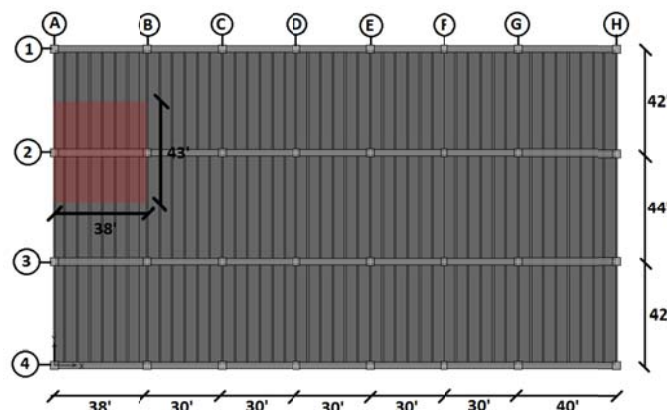

Figure 5 - 1: Iteration #1: Initial floor plan layout

Upon implementing an Excel spreadsheet and sizing the girders (more on that later), it was discovered that the girder shown in Figure 5.1 above could not support the highlighted tributary area without encountering bar spacing, and tension controlling issues. The option of adding another set of columns, shown below in Figure 5.2 was considered. This option reduced the tributary area of the girders in question but was discarded since adding additional columns would encroach on the open floor plan. Finally, the floor plan layout in Figure 5.3 was developed. By switching the direction that the pan joists span along the eastern and western most bays, this floor plan was able to further reduce the tributary area of the columns in question without adding any additional columns. The next section will provide more details on how the gravity system for this building was designed.

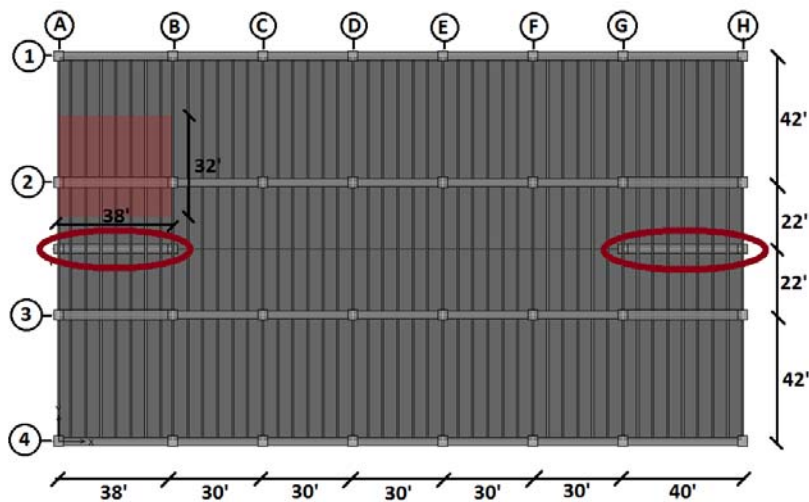

Figure 5 - 2: Iteration #2

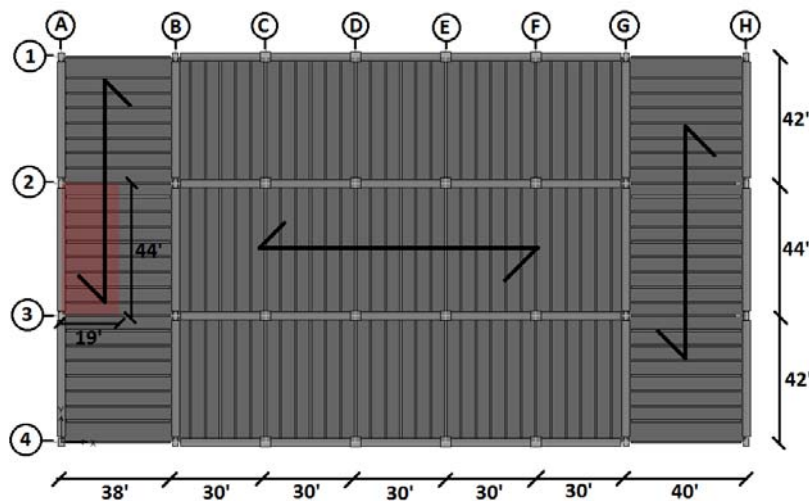

Figure 5 - 3: Iteration #3: Final Gravity System Design

Gravity System Design

Floor System

The floor system for the North Shore Equitable Building was redesigned using a number of different resources. To begin the design of the floor system, slab, joist and girder sizes were estimated with the aid of *Concrete Floor Systems: Guide to Estimating and Economizing* by David Fanella (Figure 5-4 below). Using an approximate bay size of 30' x 40', the slab was taken as 4.5" deep with a self-weight of 56.25 psf. Joist, girder, and column widths were estimated as 7", 40" and 40" respectively. Hand calculations for a 30' x 44' bay then confirmed that these sizes were adequate to carry the applied loads.

One-Way Joist – 53" pan					$f'_c = 4,000 \text{ psi}$	$SIDL = 20 \text{ psf}$	
					Slab $h = 4\frac{1}{2}"$		
					LL = 100 psf		
Bay Size (ft)	Pan Depth (in.)	Rib Width (in.)	Beam Width (in.)	Square Column Size (in.)	Concrete (ft ³ /ft ²)	Reinforcement (psf)	Pan Area (%)
20 x 20	16	7	22	22	0.68	2.35	89
20 x 25	16	7	24	24	0.67	2.43	91
20 x 30	16	7	26	26	0.65	2.51	91
20 x 35	16	7	32	32	0.65	2.76	91
20 x 40	16	7	34	34	0.64	2.95	92
25 x 25	16	7	28	28	0.68	2.60	89
25 x 30	16	7	32	32	0.67	2.66	90
25 x 35	16	7	34	34	0.66	3.10	90
25 x 40	16	7	36	36	0.65	3.52	91
30 x 30	16	7	34	34	0.67	3.03	89
30 x 35	16	7	38	38	0.67	3.24	89
30 x 40	16	7	40	40	0.66	3.53	90
35 x 35	20	7	40	40	0.76	3.27	89
35 x 40	20	7	42	42	0.74	3.48	90
40 x 40	20	7	44	44	0.75	4.01	89
45 x 45	24	7	44	44	0.82	4.10	90
50 x 50	24	7	60	48	0.85	4.99	89

Figure 5 - 4: Design table courtesy of
Concrete Floor Systems: Guide to Estimating and Economizing by David Fanella

Once preliminary sizes had been decided upon and simple hand calculations conducted, a Microsoft Excel spreadsheet was developed to confirm the adequacy of slab and member designs for all grid locations. Given the symmetrical nature of the building, four bay types and four girder types were approximated based on similar tributary areas and moment coefficients from ACI chapter 8. This spreadsheet was used to check moment capacity, reinforcing, tension controlled sections and bar spacing for slab, pan joist and girder dimensions of each of these types. Subsequent hand calculations were used to check member deflections. Exterior wall loads were taken as the load applied at the first level. Because the first level is 17' 2" in height (as compared to 13' 0" for a typical upper level) this is the controlling load case. Figures 5.5 and 5.6 on the following page show the assignments for bay type and girder type respectively.

Shown in Figure 5.7 below is a screen shot of the Excel spreadsheet calculations performed for one bay type and one girder type. Calculations for all four of the bay and girder types, for both floor and roof loads can be found in Appendix A.

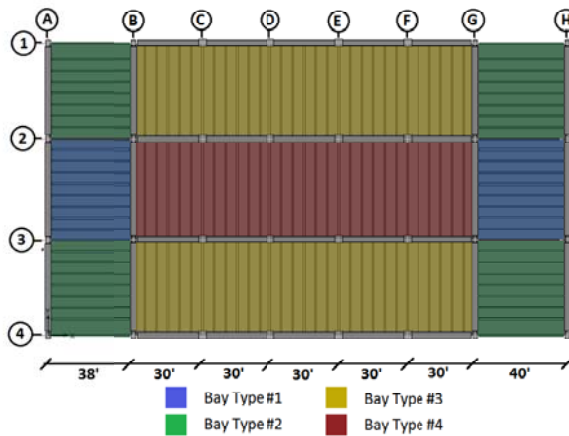

Figure 5 - 5: Bay Types as applied to the design spreadsheet

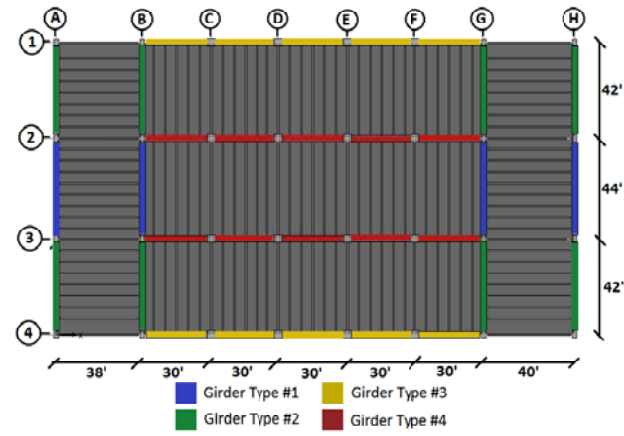

Figure 5 - 6: Girder types as applied to the design spreadsheet

Bay Type: 1		Design Parameters		Bay Type 1	
(// to joists) (x-axis) 40 ft (perp to joists) (y-axis) 44 ft Bay type: exterior		slab thickness: 4.5 in pan size: 53 in pan depth: 20 in rib width: 7 in girder width: 40 in Column size: 40 in		Girder Type: 1 Interior Span	
Design Slab slab self weight = 56.25 psf joist/slab area = 2.847 ft ² joist/slab self weight = 85.4167 psf girder self weight = 1020.83 lb/ft Dead Load = 0.07625 k/ft ² Live Load = 0.08 k/ft ² w _u = 1.2DL + 1.6LL = 0.2195 k/ft ² Min reinf = .0018A _s = 0.0972 in ² /ft width Try #3 bars @ 12" spacing Bar Area = 0.11 in ² Is A _s > A _{s,req} ? yes, ok l _n = 4.42 ft Mu = w _u l _n ² /10 = 0.428 ft.k/t width a = A _s f _y /.85f' _c b = 0.162 in φM _n = φA _s F _y (d-(a/2)) = 1.07371 ft/k Is φM _n > M _u ? YES, OK Required bot reinf = 1.92 in ² Try 1 #14 bottom bar A _s (in ²) = 2.25 Is A _s > A _{s,req} ? YES, OK bar diameter = 1.27 in depth = 21.99 in 67 B _{eff} = 79 67 117 a = A _s f _y /.85f' _c b = 0.593 in c = a/β ₁ = 0.697 in ε _s = (d-c)/c = 0.0916 Does Tension Control? YES, OK φM _n = φA _s F _y (d-(a/2)) = 219.65 ft/k Is φM _n > M _u ? YES, OK		f' _c = 4000 psi Steel F _y = 60 ksi conc weight = 150 pcf SDL = 20 psf LL = 80 psf Design Pan Joists Dead Load = 0.527 k/ft Live Load = 0.400 k/ft w _u = 1.2DL + 1.6LL = 1.273 k/ft l _n = 36.67 ft  M _u (exterior) = 71.28 ft.k M _u (interior) = 171.08 ft.k M _u (midspan) = 122.20 ft.k Design reinforcement depth = 22.25 in Required top reinf = 1.37 in ² Try 1 #11 top bar A _s (in ²) = 1.56 Is A _s > A _{s,req} ? YES, OK ρ = A _s /bd = 0.0100 a = A _s f _y /.85f' _c b = 3.933 in c = a/β ₁ = 4.627 in ε _s = (d-c)/c = 0.0114 Does Tension Control? YES, OK φM _n = φA _s F _y (d-(a/2)) = 142.39 ft.k Is φM _n > M _u ? YES, OK		Wall Load = 0.9 k/ft Dead Load = 3.74 k/ft Live Load = 1.60 k/ft w _u = 1.2DL + 1.6LL = 7.05 k/ft M _u (interior) = 1060.42 ft.k M _u (interior) = 1060.42 ft.k M _u (midspan) = 729.04 ft.k depth = 22 in Required top reinf = 12.05 in ² Try 10 #10 top bars A _s (in ²) = 12.7 Is A _s > A _{s,req} ? YES, OK # of bars = 10 d _s = 1.27 a = A _s f _y /.85f' _c b = 5.60 c = a/β ₁ = 6.59 Does Tension Control? YES, OK ε _s = 0.005 φ = 0.9 Recalculated depth = 21.865 in φM _n = φA _s F _y (d-(a/2)) = 1089.48 ft.k Is φM _n > M _u ? YES, OK Check bar spacing OKAY Required bot reinf = 8.28 in ² Try 9 #9 bot bars A _s (in ²) = 9 Is A _s > A _{s,req} ? YES, OK # of bars = 9 d _s = 1 Check bar spacing OKAY a = A _s f _y /.85f' _c b = 3.97 c = a/β ₁ = 4.67 Does Tension Control? YES, OK Recalculated depth = 22.125 in φM _n = φA _s F _y (d-(a/2)) = 815.66 ft.k Is φM _n > M _u ? YES, OK	

Figure 5 - 7: Portion of design spreadsheet showing Bay Type 1 and Girder Type 1 designs

Using results from the spreadsheet, the slab, pan joist and girder sizes were finalized. Reinforcement was sized for each of these elements as well. Elevated floor slabs at all levels have a depth of 4.5" reinforced with #3 bars spaced at 12" o.c. running normal to the joists. Pan joists are designed with a 7" depth spaced at 60" o.c. Pan joists at all levels are reinforced with 1 #14 bottom bar per joist. Top reinforcement consists of 1 #11 bar per joist in bay types 1 and 2 and 1 #14 bar per joist in bay types 3 and 4. These large reinforcement sizes are the result of bar spacing issues with a 2 #9 bar design. Rather than increase the pan joist width to 8 in, the decision was made to use #14 bars. A detail of the typical slab and pan joist system is shown below in Figure 5-8.

SLAB/PAN JOIST DETAIL

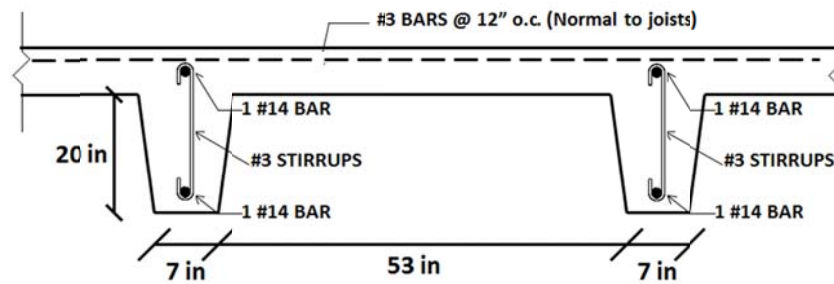

Figure 5 - 8: Slab/Pan Joist Detail

Girders are sized similarly at each level as well. Girders spanning 44' at each level are 40" wide and 24.5" deep. Girders at all other locations are 24.5" x 32". Girder reinforcing consists of #9 and #10 reinforcing for girders spanning in the transverse direction and #8 reinforcing for girders spanning in the longitudinal direction. Shown in Figure 5-9 below is a typical floor plan showing girder sizes at all levels. Figure 5-10 shows section cuts of all four girder types.

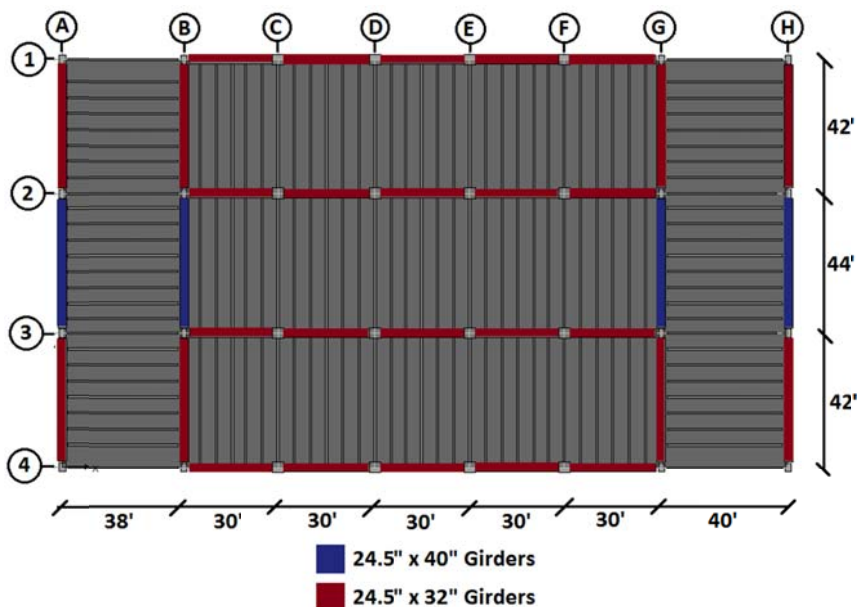

Figure 5 - 9: Typical Floor plan Girder Sizes

GIRDER DETAILS

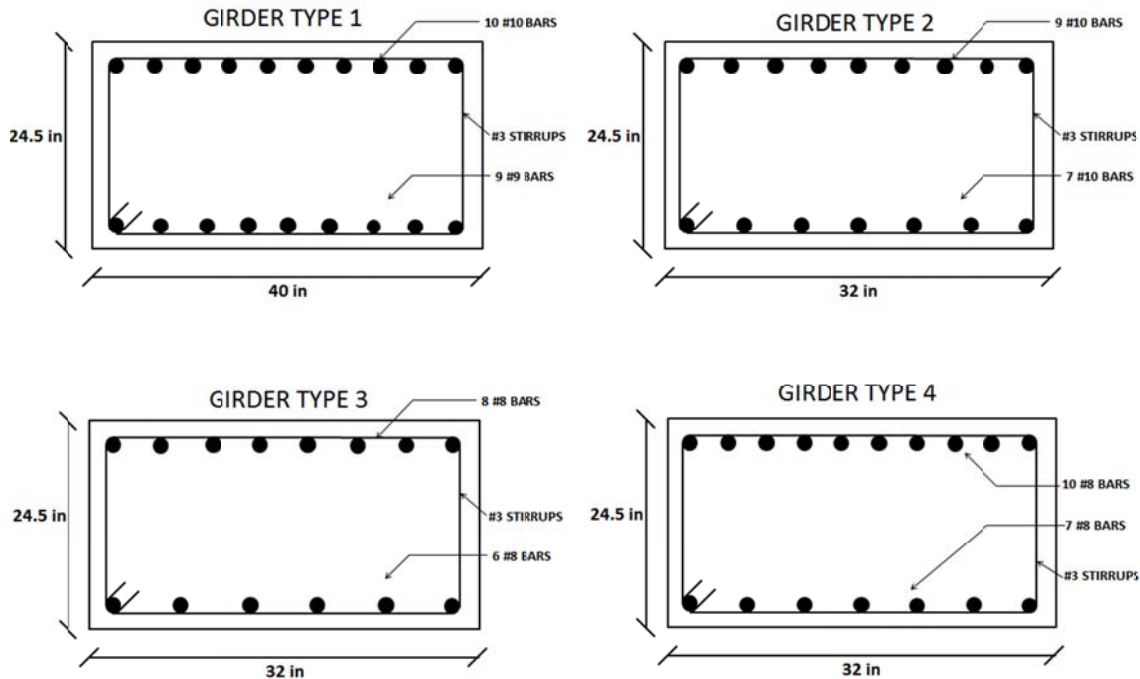

Figure 5 - 10: Final Girder Design Sections

In addition to the general framing members of the floor system, specific members framing around the stairwells and elevator shafts were designed as well. Although some concrete buildings will use steel members or shear walls to frame stairs and elevators, the decision was made to stick with normal weight concrete beams and girders for this design. Members framing the stairwells and elevator shaft were designed by hand. Shown on the following page in Figure 5-11 is a partial framing plan of a typical floor level. This framing plan shows the framing for the main stairwell and elevator core of the building. Table 5.6 below summarizes the member sizes and reinforcement.

Table 5.6 – Stairwell and Elevator Framing Members

Member Size	Span	Top Reinf.	Bottom Reinf.
24.5" x 24" Beam	42' – 44'	8 #8 Bars	5 #8 Bars
24.5" x 20" Beam	20'	6 #6 Bars	4 #6 Bars
24.5" x 16" Beam	30'	4 #8 Bars	4 #8 Bars

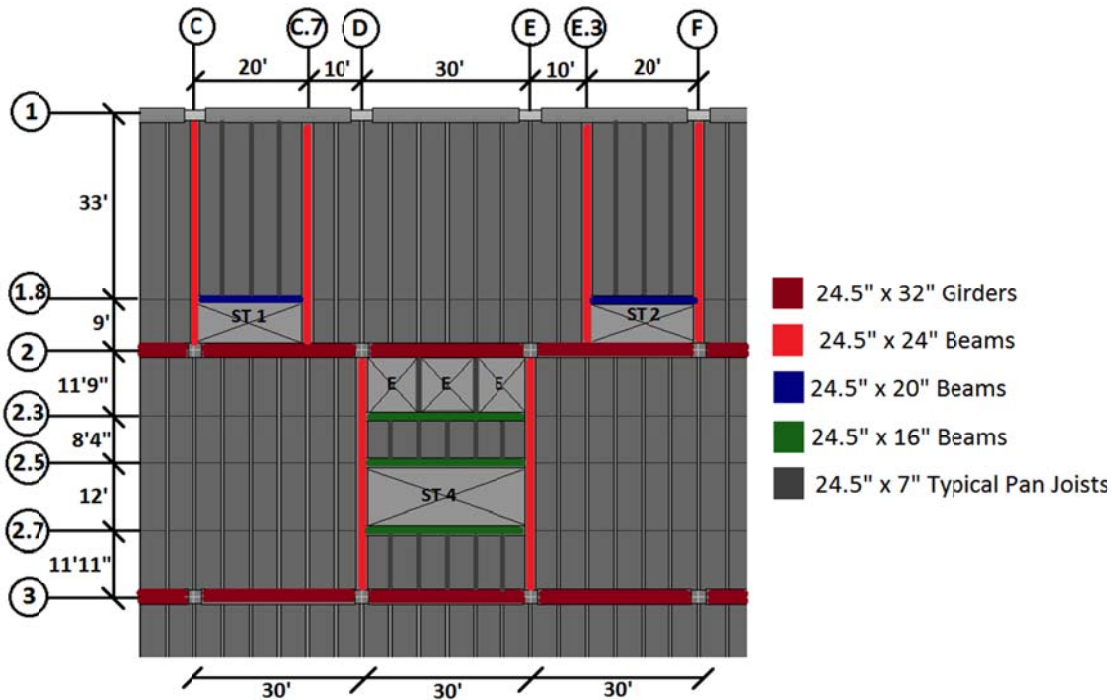

Figure 5 - 11: Partial Plan of Building Core Framing Members

Roof System

The roof system is design similarly to the floor system, using the same spreadsheet to conduct member sizing calculations. Due to a smaller applied dead load, the pan joists at the roof level have a depth of 16" (as compared to 20" at all floor levels). Loads resulting from mechanical equipment transfer directly into columns as axial load and are not applied to girders or pan joists. Pan joists for bay types 1 and 2 are reinforced with 2 #8 bars at both the top and bottom. Pan joists for bay types 3 and 4 are reinforced with 1 #14 bar at both the top and bottom. Girders spanning in the transverse direction (types 1 and 2) are 28" x 24.5" and girders spanning longitudinally (types 3 and 4) are 24" x 24.5". All girders at the roof level use #8 bars for both top and bottom reinforcing.

Columns

The columns were designed for this building using a combination of SPcolumn, an EXCEL spreadsheet, ETABS model outputs, and hand calculations.

To begin the column design process, hand calculations for a typical column were performed for the first level. This was done by finding the tributary area for each column, calculating distributed loads applied to this area and summing the loads to find the resulting factored axial force applied to the column. Distributed loads taken from the girder and slab design calculations were applied to this calculation. Estimated column weights for stories above the column in question were also added to the dead load. Once the unfactored dead and live axial loads were found, a live load reduction calculation was performed. The forces were then summed and the resulting factored axial loads were found. These axial forces, along with moments found from the ETABS model output were then used to size the column and reinforcement. These calculations can be found in Appendix B. Once hand calculations were performed for selected columns, the same basic calculation procedure was applied in an EXCEL spreadsheet to find the axial forces for each column at each level. This spreadsheet can be found in Appendix B as well. Column sizes and reinforcement were also checked using SP Column. Shown below in Figure 5-12 are typical column sections for the 1st level along with their interaction diagrams as found using SP Column. Please note that axes on the interaction diagram below are not scaled for each individual column, rather, it is a generic interaction diagram showing where each loading condition falls on its respective diagram.

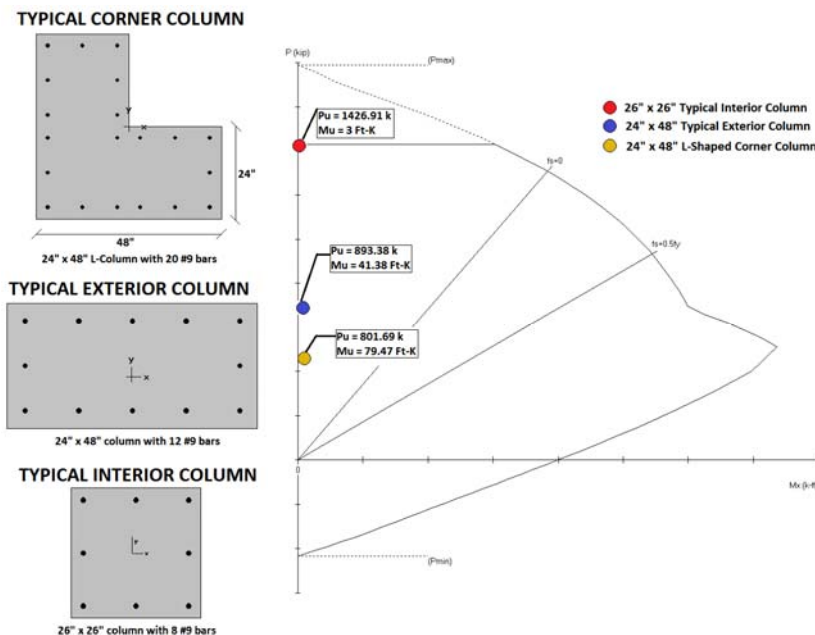

Figure 5 - 12: Typical Column sections as seen in SP Column

Originally, square columns designed to carry axial loads were used at all locations. Issues with the building period of vibration however resulted in rectangular and L-shaped columns being used in addition to square columns to add stiffness to the building. The columns' contribution to the building's lateral design will be covered in more detail in the lateral portion of this report. 24" x 48" L-shaped columns are used at each corner of the building at all levels. All other exterior columns consist of 24" x 48" rectangular columns oriented so that they do not extend into the floor space. All exterior columns are designed to maintain a 1% reinforcement ratio and, as a result, are over designed for gravity loads and gravity induced moments.

Due to varying tributary areas and axial loads throughout the building, interior columns have been designed using various sizes as well. Shown below in Figure 5-13 is the column plan for level 1. Figure 5-14 on the following page is an elevation at grid line 2 showing the change in column size with increasing floor level. The interior columns sizes gradually decrease from 30"x30" at the 1st level to 20"x20" at the 6th level. Additional hand calculations, EXCEL spreadsheet outputs and SPcolumn outputs can be seen in Appendix B.

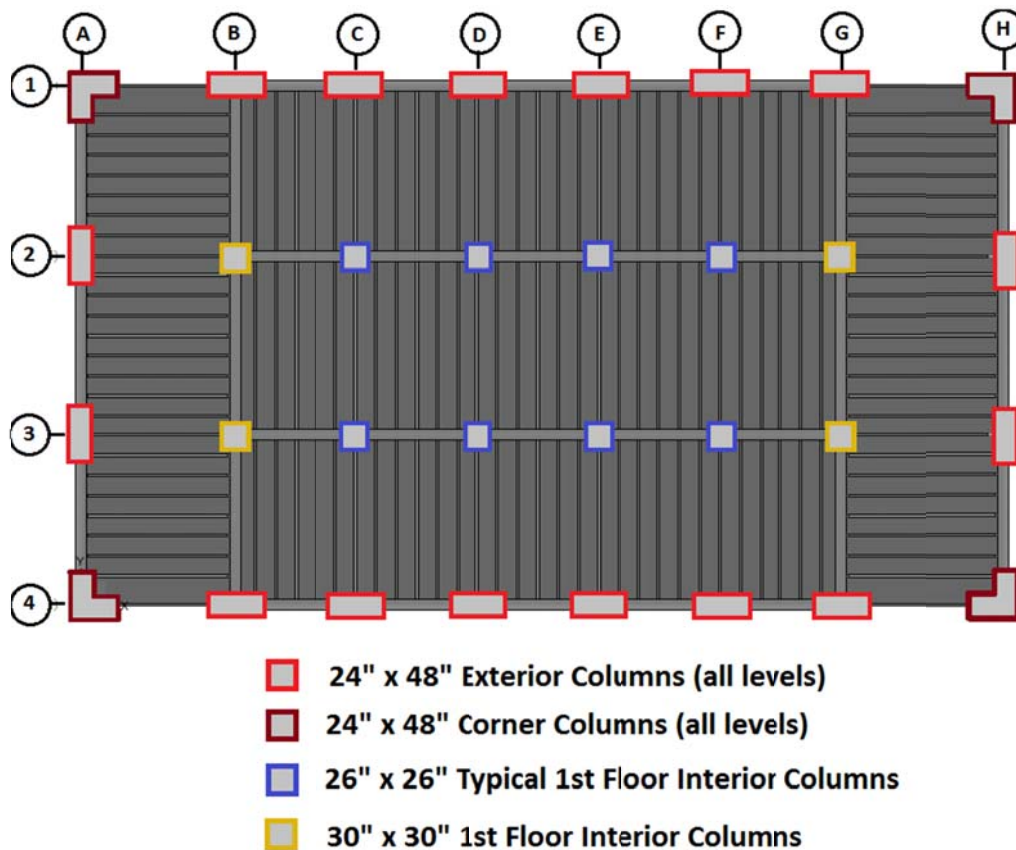

Figure 5 - 13: Level 1 Column Plan

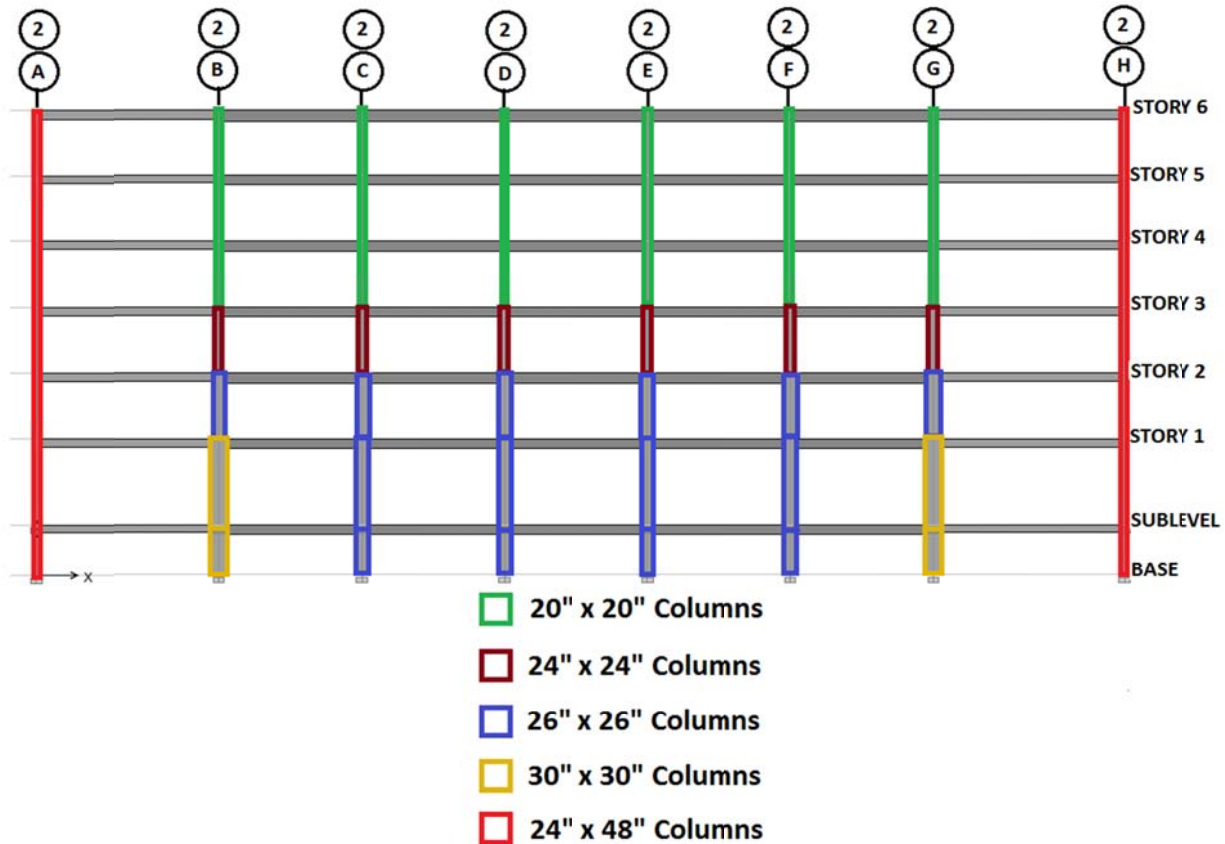

Figure 5 - 14: Building Elevation Showing Columns at Gridline 2

Final Gravity System Design

Through the use of a one way concrete pan joist and beam system, the existing grid system was able to be maintained in the redesigned gravity system. This is crucial to the feasibility of the new design given its impact on the subgrade light rail transit line and usable open office space. Furthermore, spanning pan joists in both the longitudinal and transverse directions allows for large tributary areas to be decreased in exterior bays. One of the largest changes brought about by the redesigned floor system is a reduction in building height. For the existing system, the floor system depth can be taken as 35.5" deep due to a W30 member (deepest in the building) combined with the 5.5" thick composite slab. The redesigned concrete system however combines a 4.5" concrete floor slab with 20.5" deep pan joists and girders for an overall floor thickness of 24.5". This reduction of roughly 10" per floor level (and 14" at the roof level) results in a new building height of 81'9" (compared to 87'1" for the original design). This will have an impact on both the building lateral system and the cost analysis.

Proposed Lateral System

The redesigned lateral system of the North Shore Equitable building consists of concrete moment frames supplemented with 24" x 48" columns oriented in both axes. Initially, the choice to use ordinary concrete moment frames was made because this lateral system was already integrated into the structure following the design of the gravity system. The lateral system was designed with the aid of an ETABS computer model, Excel spreadsheets to calculate wind and seismic forces, and hand calculations.

After developing and analyzing an ETABS model, it became apparent that additional stiffness was necessary. This was achieved through the use of 24" x 48" rectangular columns and 24" x 48" corner columns. The addition of these columns, along with a reduction in floor height, brought the building period under 3 seconds, which is a reasonable period for a building of this height. Concrete shear walls were considered as another alternative but, based on the location of the stairwells, framing them with shear walls would introduce torsion into the design, which should be avoided. The decision was made to forgo shear walls and minimize torsion at the expense of a slightly higher building period. To check the lateral system for effectiveness, story forces due to wind and seismic loads were calculated and applied to an ETABS model to check deflections and the building period of vibration. A more detailed description of these steps is given in the sections that follow.

Wind Loads

Wind loads were calculated using the ASCE 7-05 Main Wind-Force Resisting System analytical procedure method 2. ASCE 7-10 chapter 26.9 was referenced to determine if the building was a rigid or flexible structure. Using ASCE 7-10, the approximate frequency for a concrete moment resisting frame was calculated. This frequency turned out to be less than one, classifying the building as a flexible structure, just as with the steel braced and moment frames of the existing design. Once the building period was approximated, the wind loads were calculated using the Main Wind-Force Resisting System guidelines for flexible structures. From these calculations it was found that the North South Direction controlled since a larger building face is exposed to the wind in this direction, just as with the existing design. Wind loads for the alternate design turned out to be just less than the loads for the existing design. With the change from composite steel to normal weight concrete, the approximate natural frequency decreased from 0.861 Hz to 0.827 Hz, decreasing the gust effect factor and ultimately the story forces. The decrease in floor to floor height further decreased the story forces at each level. Table 5.7 shows the results of the calculations. Detailed hand calculations can be found in Appendix C.

The following several pages show tables and elevation views of wind loads and wind story forces for both the North/South and East/West directions.

TABLE 5.7 - Wind Analysis Design Criteria

Basic Wind Speed	90 mph
Building Classification	II
Importance Factor (I)	1.0
Exposure Category	C
Mean Height (h)	81.75 Ft.
Building Length (L)	128 Ft. for N/S
Building Base (B)	228 Ft. for N/S
Ridges or Escarpments?	None
Structure Type	Flexible
R value	3.0

TABLE 5.8 - Windward Pressures In The East/West Direction

Level	Height (Ft.)	K_z	q_z (psf)	Windward Pressure (psf)
Level 1	0.00	0.00	0.00	10.58
Level 2	17.17	0.87	15.39	10.58
Level 3	30.17	0.98	17.33	11.91
Level 4	43.17	1.06	18.69	12.84
Level 5	56.17	1.12	19.76	13.58
Level 6	69.17	1.17	20.64	14.18
Roof	81.75	1.21	21.38	14.69
Tower	94.00	1.25	22.02	15.13
Turret	103.00	1.27	22.45	15.43

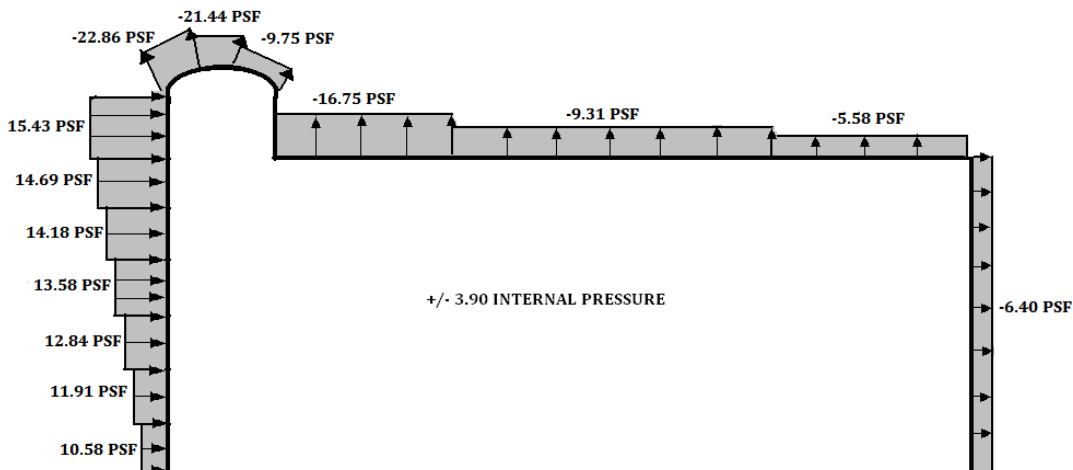

Figure 5-15: East/West Wind Pressure Elevation View

TABLE 5.9 - Windward Pressures In The North/South Direction

Level	Height (Ft.)	K _z	q _z (psf)	Windward Pressure (psf)
Level 1	0.00	0.00	0.00	10.41
Level 2	17.17	0.87	15.39	10.41
Level 3	30.17	0.98	17.33	11.72
Level 4	43.17	1.06	18.69	12.64
Level 5	56.17	1.12	19.76	13.36
Level 6	69.17	1.17	20.64	13.95
Roof	81.75	1.21	21.38	14.45
Tower	94.00	1.25	22.02	14.88
Turret	103.00	1.27	22.45	15.17

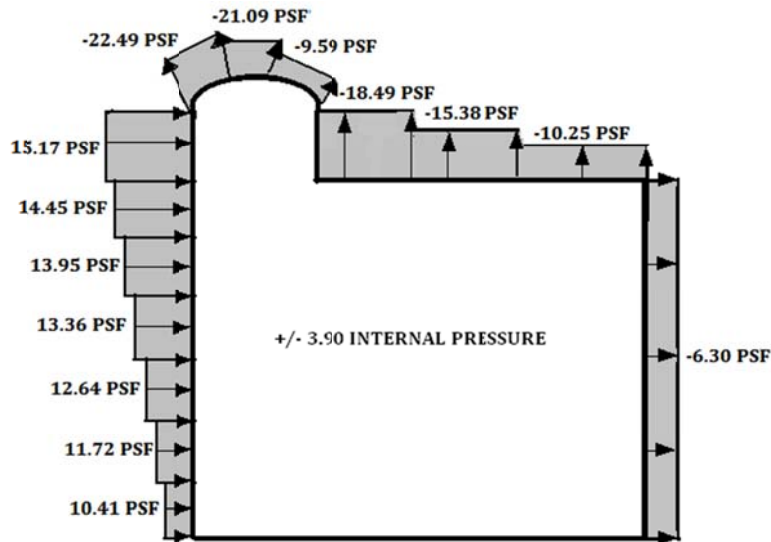

Figure 5-16: North/South Wind Pressure Elevation View

TABLE 5.10 - Wind Pressures Independent Of Height (East/West Direction)

Pressure	q value	C _p value	G value	Pressure (psf)
Leeward	21.67	-0.34	0.859	-6.40
Sidewall	21.67	-0.70	0.859	-13.03
Roof from 0 to 81.75*	21.67	-0.90	0.859	-16.75
Roof from 81.75 to 163.5*	21.67	-0.50	0.859	-9.31
Roof from 163.5 to 228*	21.67	-0.30	0.859	-5.58
Dome at point A	22.69	-1.17	0.859	-22.86
Dome at point B	22.69	-1.10	0.859	-21.44
Dome at point C	22.69	-0.50	0.859	-9.75

* Distances given are horizontal distances in feet from windward edge

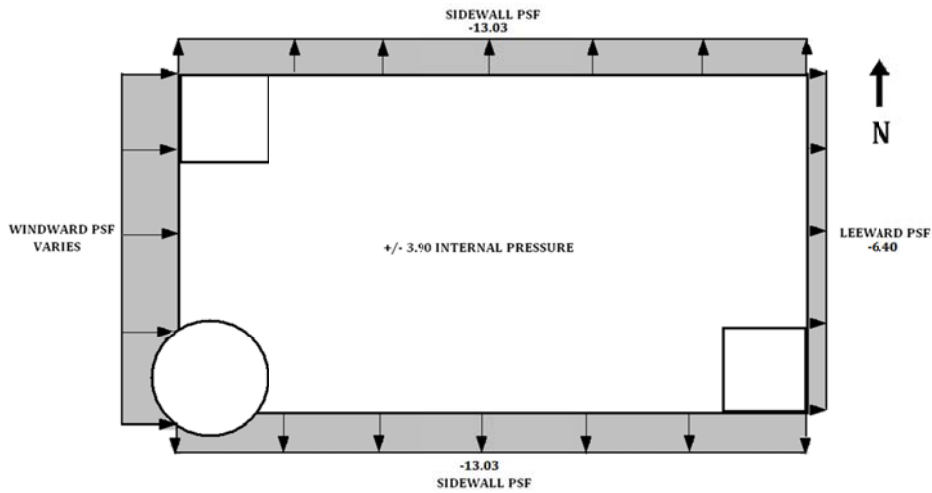

Figure 5-17: East/West Wind Pressure Plan View

TABLE 5.11 - Pressures Independent Of Height (North/South)

Pressure	q value	Cp	G	Pressure (psf)
Leeward	21.67	-0.34	0.845	-6.30
Sidewall	21.67	-0.70	0.845	-12.82
Roof from 0 to 43.54*	21.67	-1.01	0.845	-18.49
Roof from 40.88 to 81.75*	21.67	-0.84	0.845	-15.38
Roof from 81.75 to 128*	21.67	-0.56	0.845	-10.25
Dome at point A	22.69	-1.17	0.845	-22.49
Dome at point B	22.69	-1.10	0.845	-21.09
Dome at point C	22.69	-0.50	0.845	-9.59

* Distances given are horizontal distances in feet from windward edge

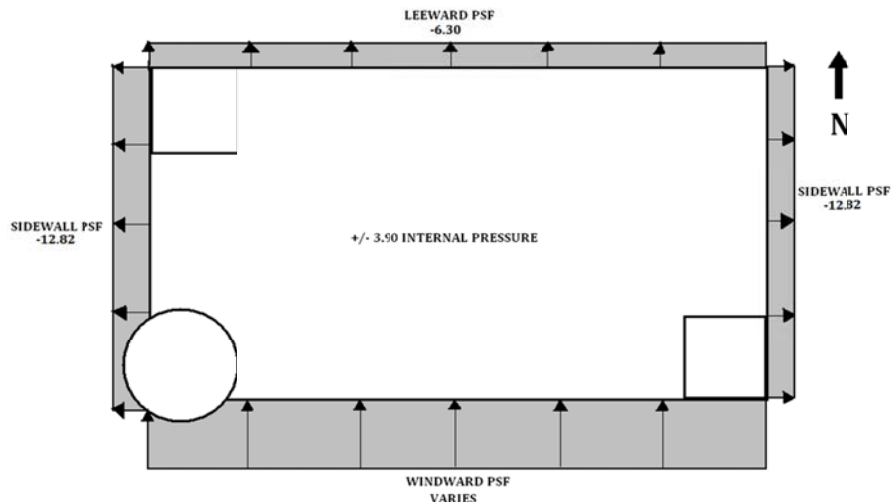

Figure 5-18: North/South Wind Pressure Plan View

TABLE 5.12 - Story Wind Forces (East/West Direction)

Level	Height (Ft.)	Face Length (Ft.)	Elevation (Ft.)	Pressure (psf)	Story Force (K)	Story Shear (K)
Turret	8.13	22.67	103	15.43	2.84	2.84
Roof	6.88	128	81.75	14.69	12.94	15.78
Level 6	12.58	128	69.17	14.18	22.84	38.62
Level 5	13.00	128	56.17	13.58	22.59	61.21
Level 4	13.00	128	43.17	12.84	21.37	82.59
Level 3	13.00	128	30.17	11.91	19.82	102.41
Level 2	15.08	128	17.17	10.58	20.42	122.83
Level 1	8.58	128	0	10.68	11.73	134.56

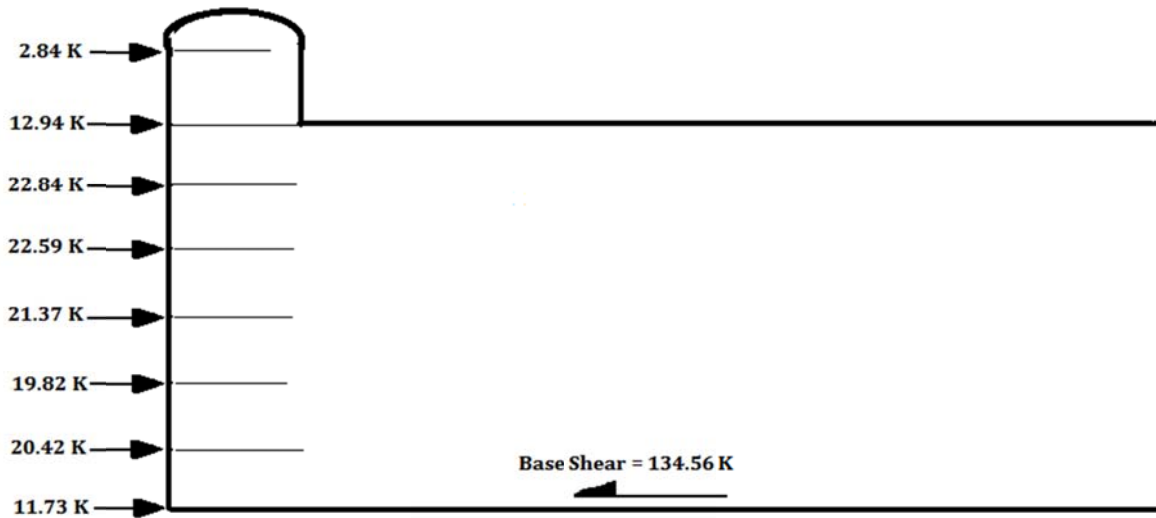

Figure 5-19: East/West Wind Story Forces

TABLE 5.13 – Story Wind Forces (North/South Direction)

Level	Height (Ft.)	Face (Ft.)	Elevatio (Ft.)	Pressure (psf)	Story (K)	Story (K)
Turret	8.13	22.67	103	15.17	2.80	2.80
Roof	6.88	228	81.75	14.45	22.67	25.47
Level 6	12.58	228	69.17	13.95	40.02	65.49
Level 5	13.00	228	56.17	13.36	39.59	105.08
Level 4	13.00	228	43.17	12.64	37.45	142.53
Level 3	13.00	228	30.17	11.72	34.73	177.26
Level 2	15.08	228	17.17	10.41	35.78	213.03
Level 1	8.58	228	0	10.51	20.56	233.59

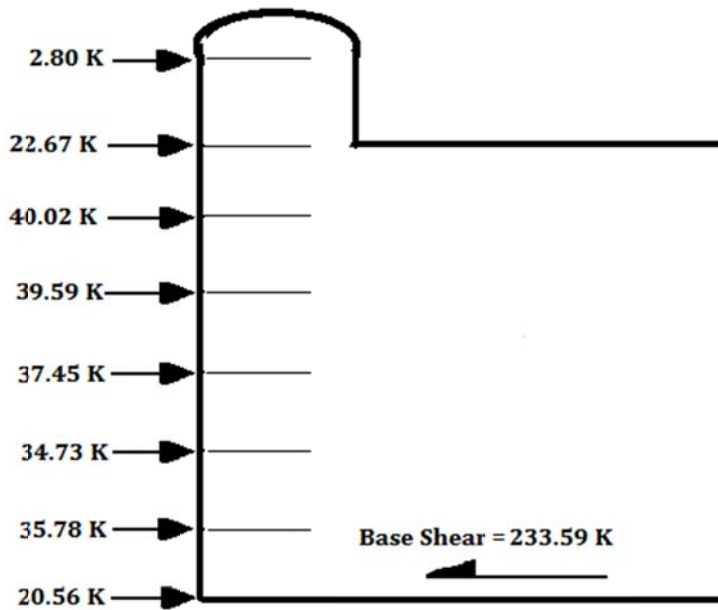

Figure 5-20: North/South Wind Story Forces

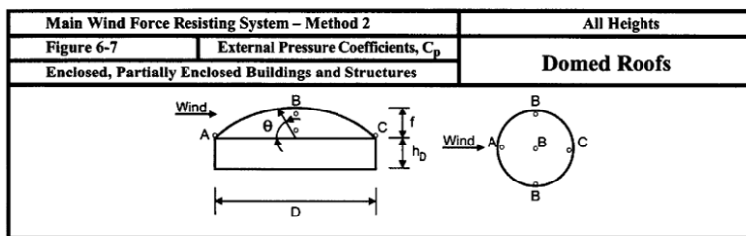

Figure 5-21: ASCE 7-05 Domed Roof Excerpt

Seismic Forces

The seismic loads for the North Shore Equitable Building were calculated using ASCE 7-05's equivalent lateral force procedure. For this evaluation, no ASCE 7-05 factors changed except the estimated period. The estimated period changed from 2.019 seconds to 1.763 seconds. This is due to the C_t and x values changing based on a change from steel moment frames to ordinary concrete moment frames.

The building weight, however, changed significantly. Due to the switch from steel to concrete, the building weight nearly doubled, increasing from 16987 kips to 32666 kips. This led to an increase of the seismic base shear from 261.6 kips to 672.92 kips which in turn lead to significantly increased story forces at each level. The decrease in building height helped decrease the story forces to a certain extent but the overall result was still an increase in the story forces. Building weight calculations can be seen in Table D.5 of Appendix D. As with the technical reports, the stairwell weights were excluded to simplify calculations. This can be done since assuming a continuous slab with no openings across the entire plan results in a heavier weight and thus is conservative.

In Tech report 3, it was found that wind was the controlling force of the existing design. With the increase in building weight, the seismic base shear is now greater than the wind base shear. Even though the seismic story forces for the redesigned system are much larger than the wind story forces, this building is designed for a seismically inactive region, so for all intensive purposes, wind can still be considered the controlling load case. The results of the seismic analysis can be seen on the next page.

TABLE 5.14 - Story Seismic Forces

Level	Story Weight	Story Height			Story Force	Story Shear
	w_x (K)	h_x (Ft.)	$w_x h_x^k$	C_{vx}	F_x (K)	V_x (K)
Level 1	5162.89	0.00	0.00	0.00	0.00	672.92
Level 2	4821.02	17.17	177814.0	0.05	30.86	672.92
level 3	4821.02	30.17	363634.6	0.09	63.11	642.06
Level 4	4821.02	43.17	573040.0	0.15	99.45	578.95
Level 5	4821.02	56.17	800313.3	0.21	138.89	479.51
Level 6	4775.62	69.17	1032488.	0.27	179.18	340.61
Roof	3300.91	81.75	882228.0	0.23	153.11	161.43
Upper	142.54	98.01	47957.76	0.01	8.32	8.32

TABLE 5.15 - Seismic Design Criteria

Site Class: D	$S_s=0.15$	$S_1=0.04$	$F_a=1.6$	$F_v=2.4$	$C_t=0.016$	$X=0.9$
	$C_u T_a=1.763s$	$T_0=0.08$	$T_s=0.4$	$T_I=12$	$R=3.0$	$C_s=0.0206$

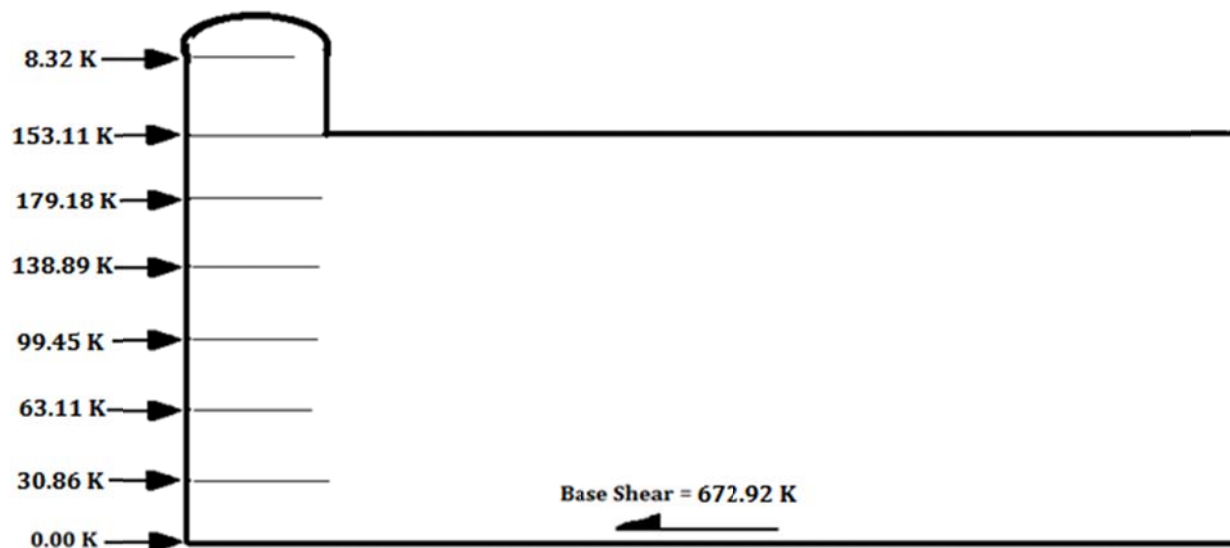

Figure 5-22 Seismic Story Forces

Computer Model Analysis

Model Description

A computer model of the redesigned structure was developed in ETABS in order to analyze both the wind and seismic loading conditions. Unlike the model developed for tech report 3, this model includes both lateral and gravity members. This is because, during the modeling process, it was discovered that the pan joists actually add a surprising amount of stiffness and can help decrease the building period by up to .2 seconds. For simplicity, the building was modeled as a rectangle, omitting the turret and tower details at each corner of the building.

The following assumptions were made when developing the model;

- Fix all columns at the base.
- Use rigid diaphragms at all upper levels.
- Set all member self-weights and masses to zero and lump the building mass in the diaphragms as an additional area mass.
- Consider cracked moment of inertia (0.7 for columns and 0.35 for beams).
- Apply rigid end offsets to all beams and columns using a rigid zone factor of 0.5.

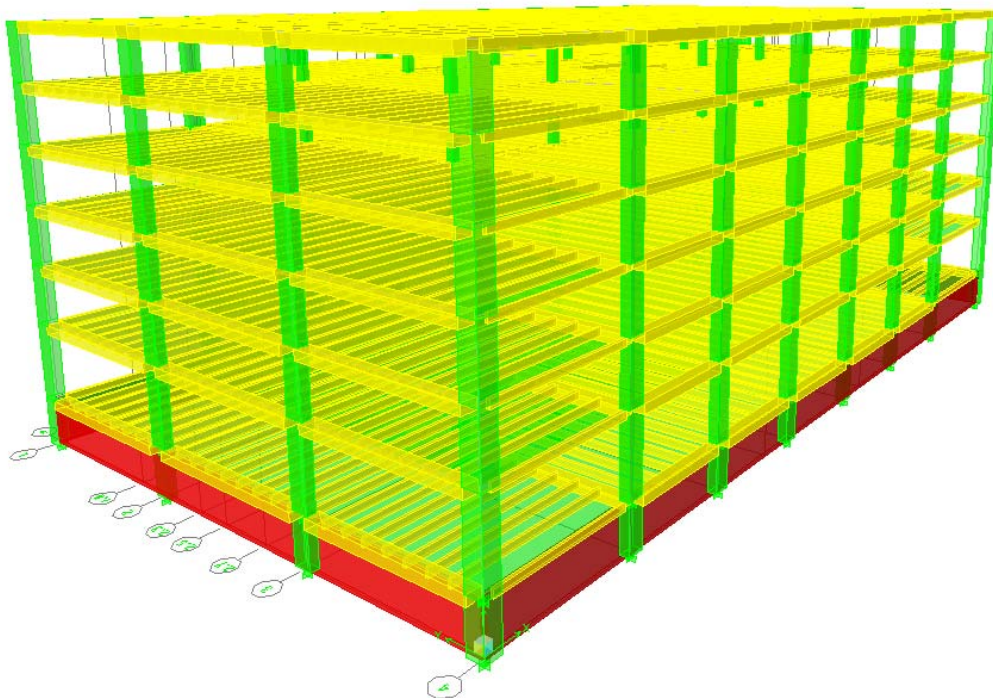

Figure 5-23: ETABS Model of the Redesigned North Shore Equitable Building

Once the building was modeled in ETABS, all loads and load cases were added. An 80 psf live load was applied to each upper level with a 100 psf live load at the first level. Both wind and seismic loads were set to “user defined” and the seismic and wind story forces from Tables 5.12, 5.13 and 5.14 of this report were input. Output data based on all of these load combinations can be found in Appendix E.

Once the model was run, the period of vibration was checked to insure accuracy of the design. Shown below in Table 5.16 are the first three modes of vibration, along with the approximated period from ASCE 7-05; 12.8.2:

TABLE 5.16 – ETABS Period Of Vibration Values (in seconds)

Redesigned Structure Output	$T_x = 2.95 \text{ s}$	$T_y = 2.56 \text{ s}$	$T_z = 2.14 \text{ s}$
Existing Structure Output	$T_x = 2.71 \text{ s}$	$T_y = 1.96 \text{ s}$	$T_z = 1.21 \text{ s}$
ASCE 7-05 Approximated Period	$C_u T_a = C_u C_t h_n^x = 1.76 \text{ s}$		

The higher periods for the redesigned system can be attributed to greatly increased floor weight at each level.

Load Combinations

Using ASCE 7-05 chapter 2, all 7 load cases were taken and applied to the ETABS model. Each load case was defined as a separate load combination for N/S and E/W wind forces as well as for seismic forces in both the N/S and E/W directions. This resulted in 13 different load combinations entered into ETABS (shown below in Table 5.17). To simplify the model analysis, roof live load, snow load and rain load have been neglected.

TABLE 5.17 – Load Combinations used in

Combo	Equation	Combo	Equation
1	1.4D	8	1.2D + 1.0 E _x + L
2	1.2D + 1.6L	9	1.2D + 1.0 E _y + L
3	1.2D + L	10	0.9D + 1.6W _x
4	1.2D + 0.8W _x	11	0.9D + 1.6W _y
5	1.2D + 0.8W _y	12	0.9D + 1.0 E _x
6	1.2D + 1.6W _y + L	13	0.9D + 1.0 E _y
7	1.2D + 1.6W _x + L		

Relative Stiffness

Four types of concrete moment frames make up the lateral system. To calculate the center of rigidity, the stiffness of each lateral frame must be found. To find the stiffness values of each frame, the frames were isolated in the ETABS model and a 100 kip point load was applied horizontally at the top right corner of each frame. The ETABS analysis was run and the resulting frame deflections were recorded. The relative stiffness values were then calculated and can be seen in Table 5.18 below. The frames and their locations can be seen in the figure below.

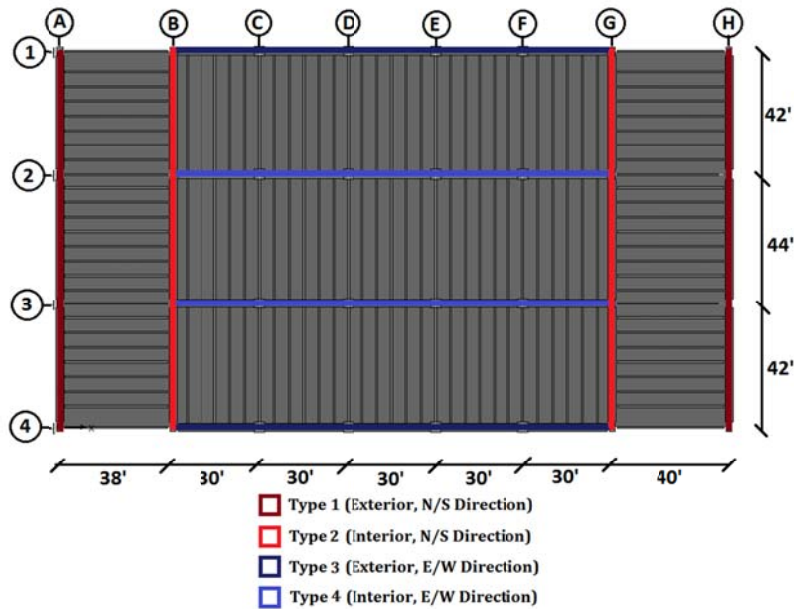

Figure 5-24: Concrete Moment Frame Location

TABLE 5.18 - Frame Stiffness Values at Level 6

Frame Type	Applied force (K)	Deflection (in)	Stiffness (K = p _i /Δ)
Type 1	100	1.5198	65.80 (K/in)
Type 2	100	1.3887	72.01 (K/in)
Type 3	100	0.5876	170.18 (K/in)
Type 4	100	0.7363	135.81 (K/in)

By observing the location of each type of frame on the plan view in Figure 5-24, it can be seen that the lateral frames of this system are symmetrical and will result in both the centers of mass and rigidity being very close to the center of the building. Therefore, it can be assumed that a torsional analysis will not be necessary for the redesigned structure. Seen on the following page is an elevation view of the deflected shape of each type of moment frame due to the 100 K applied load as seen in ETABS.

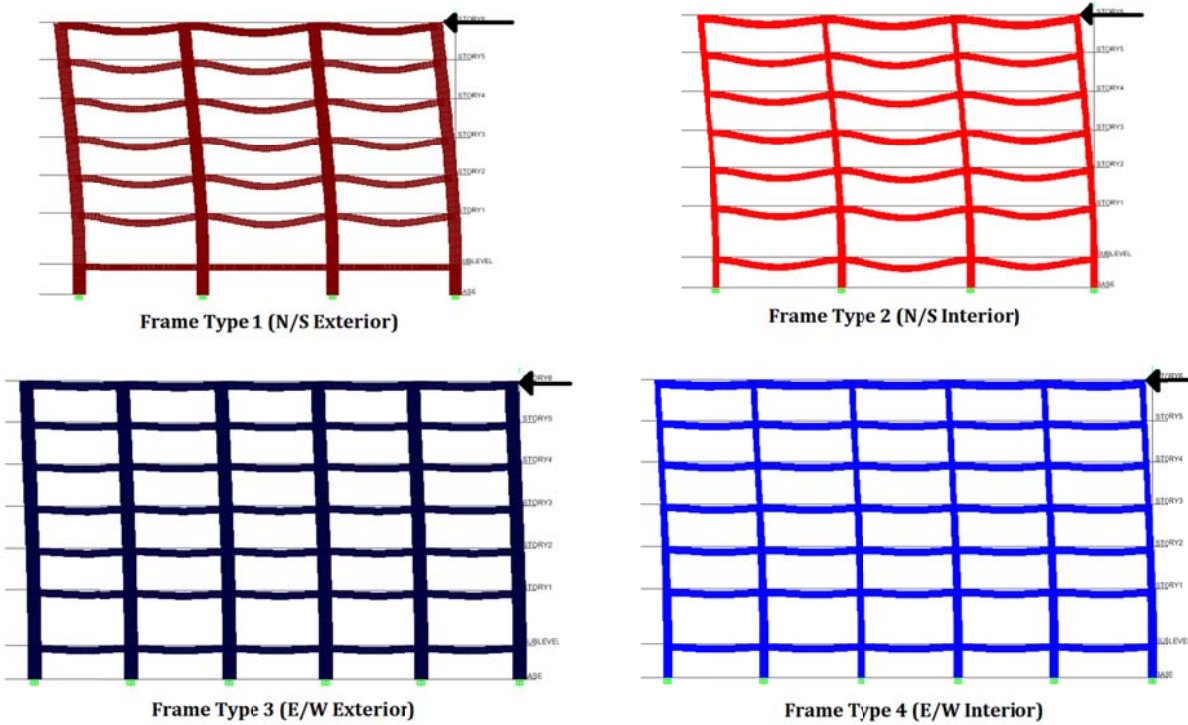

Figure 5-25: Concrete Moment Frame Deflections

Center of Mass and Rigidity

Below is the ETABS output for the center of mass and rigidity.

TABLE 5.19 – Center of Mass and Rigidity

Level Sublevel	C.O.M.		ETABS C.O.R.		Hand	
	X(Ft.)	Y(Ft.)	X(Ft.)	Y(Ft.)	X(Ft.)	Y(Ft.)
	114	64				
1	114	64	113.14	64.27	114	64
2	114	64	112.85	64.46	114	64
3	114	64	112.61	64.61	114	64
4	114	64	112.44	64.72	114	64
5	114	64	112.31	64.79	114	64
6	114	64	112.26	64.79	114	64

The slight offset in center of rigidity is most likely due to the larger sized beams framing around the stairwells. These beams are most likely contributing stiffness to the lateral system that was not accounted for in Figure 5-24 and thus are displacing the center of rigidity a slight bit.

Deflections

In order to assure that the redesigned structural system of the building achieves lateral stability, deflections must be checked and compared to acceptable industry values. Once an analysis was run of the ETABS model, deflections at each building level were found for each load case. These values were then compared to industry acceptable values of $h_x/400$ for wind loads and $0.02 h_{sx}$ for seismic loads. Shown below in Table 5.20 are the deflections for all load cases at level 6. Tables for levels 1 through 5 can be found in Appendix E. Load cases controlled by seismic forces are highlighted in blue as to not be confused with wind controlled load cases.

TABLE 5.20 - ETABS Deflections Output for Level 6

Load Combo	Δ_x (in)	Δ_y (in)	Controlling Load Case	Acceptable?
COMB1	.0063	.0058	2.453 ($h_x/400$)	Yes
COMB2	.0054	.0050	2.453 ($h_x/400$)	Yes
COMB3	.0054	.0050	2.453 ($h_x/400$)	Yes
COMB4	.2950	.0053	2.453 ($h_x/400$)	Yes
COMB5	.0060	0.6838	2.453 ($h_x/400$)	Yes
COMB6	.0066	1.3626	2.453 ($h_x/400$)	Yes
COMB7	.5846	.0056	2.453 ($h_x/400$)	Yes
COMB8	2.6378	.0080	19.62 ($0.02 h_{sx}$)	Yes
COMB9	.0084	3.5312	19.62 ($0.02 h_{sx}$)	Yes
COMB10	.5833	.0044	2.453 ($h_x/400$)	Yes
COMB11	.0052	1.3613	2.453 ($h_x/400$)	Yes
COMB12	2.6365	.0067	19.62 ($0.02 h_{sx}$)	Yes
COMB13	.0071	3.5300	19.62 ($0.02 h_{sx}$)	Yes

According to the ETABS analysis, all load combinations produce deflections that are within the acceptable range defined by industry standards. Therefore, it can be concluded that the redesigned concrete pan joist and beam system is satisfactory as far as deflections are concerned.

Final Lateral System Design

The redesigned lateral system of the North Shore Equitable Building consists of ordinary concrete moment frames supplemented with rectangular exterior columns acting as shear walls. Both wind and seismic analyses were completed and lateral forces were applied to this lateral system. Once lateral deflections were checked and a reasonable building period was obtained, it could be concluded that this design is satisfactory and meets industry standards.

Foundation Assessment

As described in the existing structure overview, the foundation of the North Shore Equitable Building consists of a combination of 18" auger cast piles and steel H-piles. Pile foundations are used in situations where the foundation needs to be extended past weak soil to a greater depth where bearing soil is able to carry the foundation load.

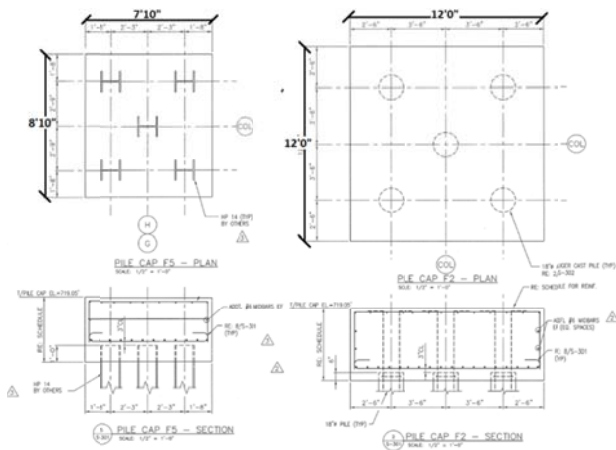

Figure 5-26: Typical Existing Auger Cast Pile and Steel H-pile

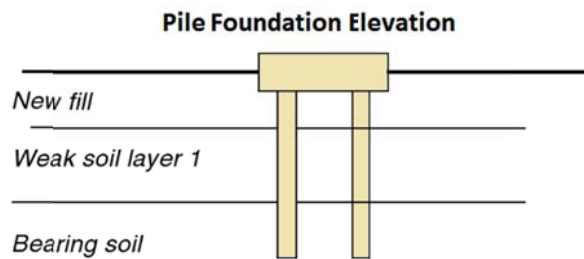

Figure 5-27: Depiction of an Ordinary Pile Foundation in Relation to Site Soil Conditions

Bearing Capacity

In the existing system, a typical auger cast pile cap (Figure 5-26, above), is designed using 5 piles to bear the axial load from the column it supports. The allowable end bearing for a typical 18" diameter auger cast pile is 145 tons (290 Kips) in the existing design. A typical pile cap then, with 5 piles can support 1450 Kips of axial load from the column above. With the increase in building weight, however, the number of piles needed to support the building load must be reevaluated.

Using the axial loads calculated in the column design spreadsheet, and adding the total axial load for the ground level and sublevel, it was found that the new axial load for a typical interior column is 2000.84 Kips. This load requires at least seven 18" piles to meet bearing capacity. Therefore, a typical pile cap will have to be redesigned using 7 piles rather than 5. A possible redesigned pile cap configuration is shown to the right. Calculations can be found in Appendix F.

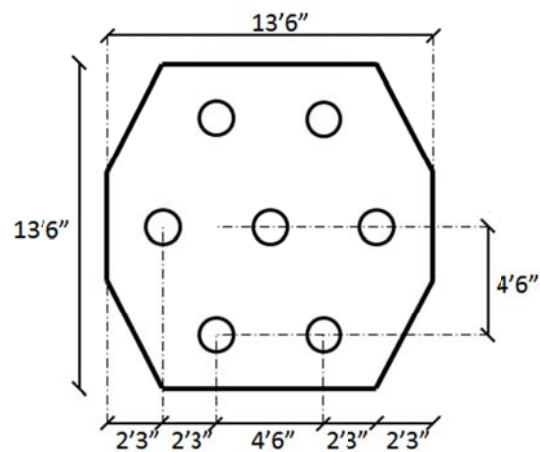

Figure 5-28: Redesigned Typical Pile Cap

Overtuning Check

In addition to bearing capacity, the overturning forces must be evaluated as well. To check the design's overturning moment, the moment caused by the wind loads in the north/south direction was taken at the base of column line A4. This value was then compared to the total dead load supported by column line A4. The concrete moment frame in gridline A was chosen for evaluation because it spans the shortest distance, is subjected to the largest wind loads, and supports the least axial load out of all moment frames. The calculation shows that the dead load is sufficiently large to prevent overturning. These calculations can be found in Appendix F.

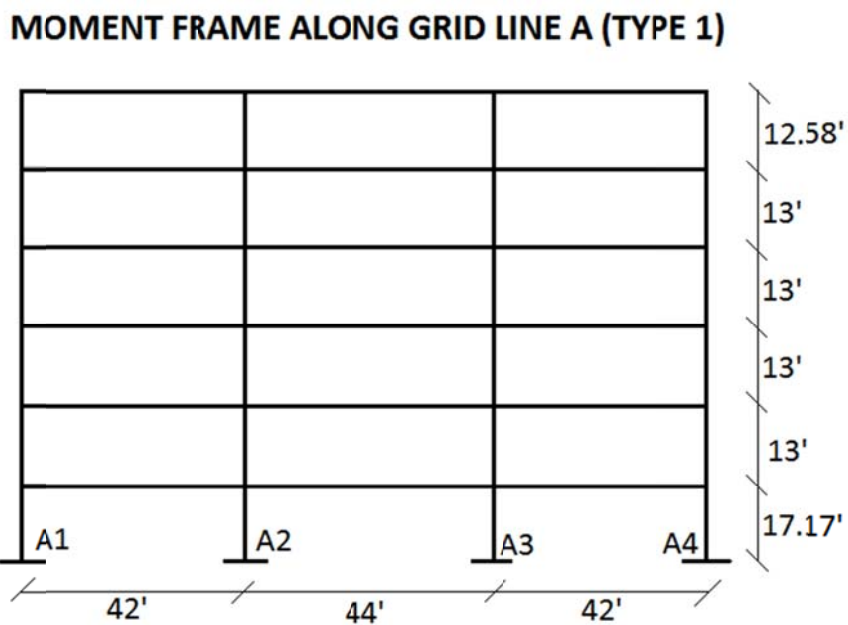

Figure 5-29: Moment Frame along Grid Line A

6. BREADTH #1: COST AND SCHEDULE ANALYSIS

Changing the design of a structure from steel to concrete will have a profound impact on both the cost and construction schedule of the building. It is for this reason that a cost and schedule analysis was performed on the redesigned system of the North Shore Equitable Building. When comparing the new and existing system, it is expected that the construction time may increase. Formwork will be necessary for the new system due to the use of concrete but steel fireproofing will no longer be needed as concrete is inherently fire resistant. The decrease in building height will also have an impact, presumably helping to lower the cost of the redesigned system. RS means cost works' website was used to conduct a detailed cost analysis of the structural system, as well as a simple square foot estimate to determine the cost impact of decreasing the building height. Rough schedules for construction of a single story of both the new and existing systems were developed as well to determine the scheduling impact of the redesigned system.

Cost Comparison

For the detailed analyses of the structures, cost data from *MasterFormat 2010* (available on rsmeanscostworks.com) was used. The location factor was set to Pittsburgh, PA and 3% General Contractor markups were used on subs, general conditions and general contractor's overhead and profit. For the steel costs analysis, spray fireproofing was included. For the concrete analysis, the concrete was assumed to be pumped. Detailed quantity takeoffs were then conducted for slabs, beams, girders and columns of both structures at all floor levels. Formwork and fireproofing was priced as well. Shown below in Tables 6.1 through 6.4 are summaries of the structural cost of each design. More detailed takeoffs can be seen in Appendix G.

Table 6.1 – Steel Cost Breakdown by Structural Element

Structural Element	Level	Quantity	Unit	Bare Material	Bare Labor	Bare Equipment	Bare Total	Total O&P	Daily Output (S.F./D)	Days
Columns	Total	2645.28	L.F.	\$ 241,990.78	\$ 4,532.07	\$ 2,750.48	\$ 249,273.34	\$ 279,441.85	1000	2.6
Floor Members	1	3440	L.F.	\$ 223,860.51	\$ 14,306.25	\$ 6,609.65	\$ 244,776.41	\$ 278,599.23	950	3.6
	2 to 6	4052.2	L.F.	\$ 257,779.39	\$ 16,711.44	\$ 7,759.28	\$ 282,250.12	\$ 322,344.46	950	4.3
	roof	3640.94	L.F.	\$ 237,533.52	\$ 13,912.32	\$ 6,851.25	\$ 258,297.09	\$ 293,969.38	950	3.8
Joist Framing	Roof	3443.1	L.F.	\$ 20,047.41	\$ 7,009.38	\$ 3,391.71	\$ 30,448.50	\$ 37,869.93	2165	1.6
18 gauge 2" floor deck	1 to 6	29184	S.F.	\$ 62,745.60	\$ 11,965.44	\$ 1,167.36	\$ 75,878.40	\$ 91,929.60	3380	8.6
20 gauge 1.5" roof deck	roof	29184	S.F.	\$ 39,690.24	\$ 9,338.88	\$ 875.52	\$ 49,904.64	\$ 61,578.24	4300	6.8
Sprayed Fireproofing										
Beams/Columns	1	19608	S.F.	\$ 9,360.24	\$ 10,457.60	\$ 1,664.96	\$ 21,482.80	\$ 13,508.47	1450	13.7
Beams/Columns	2 to 5	24784	S.F.	\$ 11,757.86	\$ 12,986.21	\$ 2,055.64	\$ 26,799.71	\$ 16,720.24	1450	17.0
Beams/Columns	6	24727	S.F.	\$ 11,727.65	\$ 12,946.31	\$ 2,043.80	\$ 26,722.76	\$ 16,666.47	1450	16.9
Beams/Columns	roof	18205	S.F.	\$ 8,556.35	\$ 9,284.55	\$ 1,455.40	\$ 19,297.30	\$ 11,893.33	1500	12.1
Roof Deck	Roof	29184	S.F.	\$ 20,720.64	\$ 18,094.08	\$ 2,913.40	\$ 41,733.12	\$ 53,406.72	1250	23.3
3.5" Composite Slab	1 to 6	315.26	C.Y.	\$ 46,973.74	\$ 4,697.37	\$ 1,743.69	\$ 53,420.81	\$ 60,561.45	140	2.3

Table 6.2 – Concrete Cost Breakdown by Structural Element

Structural Element	Level	Quantity	Unit	Bare Material	Bare Labor	Bare Equipment	Bare Total	Total O&P	Daily Output (S.F./D)	Days
Concrete Formwork	Sublevel	6272	SFCA	\$ 13,809.81	\$ 37,064.30	\$ -	\$ 50,874.11	\$ 72,702.49	195	32.0
	1 to 4	29337	SFCA	\$ 27,618.46	\$ 143,872.89	\$ -	\$ 171,491.35	\$ 253,898.83	340	87.3
	5	29337	SFCA	\$ 45,082.85	\$ 155,388.71	\$ -	\$ 200,471.56	\$ 291,161.53	500	93.2
	6	28989	SFCA	\$ 51,055.33	\$ 158,869.99	\$ -	\$ 209,925.32	\$ 303,077.71	530	96.2
Reinforcing Steel	1	85.835	Ton	\$ 80,255.73	\$ 44,780.16	\$ -	\$ 125,035.89	\$ 161,271.16	2.5	32.5
	2	82.809	Ton	\$ 77,426.42	\$ 42,964.56	\$ -	\$ 120,390.98	\$ 155,204.03	2.5	31.2
	3	82.704	Ton	\$ 77,328.24	\$ 42,901.56	\$ -	\$ 120,229.80	\$ 154,993.50	2.5	31.1
	4 and 5	82.6	Ton	\$ 77,231.00	\$ 42,839.16	\$ -	\$ 120,070.16	\$ 154,784.98	2.5	31.1
	6	82.344	Ton	\$ 76,991.64	\$ 42,685.56	\$ -	\$ 119,677.20	\$ 154,271.70	2.5	31.0
Concrete Placement	1	855.35	C.Y.	\$ 90,667.10	\$ 16,173.98	\$ 6,059.02	\$ 112,900.10	\$ 131,717.80	115	7.4
	2 to 5	821.51	C.Y.	\$ 87,080.06	\$ 15,541.17	\$ 5,822.14	\$ 108,443.38	\$ 126,516.60	115	7.1
	6	813.27	C.Y.	\$ 86,206.62	\$ 15,801.59	\$ 5,905.88	\$ 107,914.09	\$ 125,991.34	105	7.3

Table 6.3 – Total Cost for the Existing Steel Structure

Structural Element	Total O&P
Columns	\$ 279,441.85
Joists/Beams/Girders	\$ 2,184,290.89
K-Series Joists	\$ 37,869.93
18 gauge Floor Decks	\$ 551,577.60
20 gauge Roof Deck	\$ 61,578.24
Sprayed Fireproofing	\$ 162,355.94
3.5" composite floor slab	\$ 363,368.68
TOTAL EXISTING STRUCTURE	\$ 3,640,483.12

Table 6.4 – Total Cost for the Redesigned Concrete Structure

Structural Element	Total O&P
Beam Formwork	\$ 1,625,389.79
Column Formwork	\$ 271,610.67
Beam/Girder Reinf. #8 to #18	\$ 833,384.16
Column Reinf. #8 to #18	\$ 101,926.18
Slab/Joist/Girder Placement	\$ 661,558.48
Column Placement	\$ 102,217.04
TOTAL REDESIGNED STRUCTURE	\$ 3,596,086.32

From Tables 6.3 and 6.4, it can be seen that both structures have very similar total costs with the composite steel system being slightly more expensive. Accounting for the decrease in building height lowers the cost of the concrete system even further. A simple square foot estimate was conducted to check the effects of the building height decrease. Table 6.5 on the following page highlights the resulting price differences. This table shows that the decrease in building height leads to a decrease in exterior wall cost, partition wall cost, and window cost. After conducting a cost analysis, it can be seen that the redesigned concrete structure is in fact more affordable.

Table 6.5 - Cost Impact of Height Difference

System	Composite Steel	One Way Concrete
Building Height	87.08 Ft.	81.75 Ft.
Exterior Wall Cost	\$ 1,486,500.00	\$ 1,396,500.00
Exterior Window Cost	\$ 442,500.00	\$ 416,000.00
Partition Cost	\$ 432,500.00	\$ 420,500.00
Total Cost of Affected Areas	\$ 2,361,500.00	\$ 2,233,000.00
REDESIGNED STRUCTURE COST DECREASE;		\$ 128,500.00

Schedule Comparison

Typically, concrete structures take longer to erect than steel structures. This is due in part to time needed to erect formwork and get reinforcing bars in place before the concrete is placed. Curing time of concrete may need to be accounted for as well. The construction schedule for this redesigned system is no exception. Shown below is a simplified schedule for the construction of one level of the building structure. Table 6.6 shows that one floor of concrete design will take roughly twice as long as one floor of a steel design. When interpreting these results, it's important to remember that these values cannot simply be multiplied by the total number of stories to find the total construction time. This is because floor construction can overlap, with members being erected as higher levels even before slabs are placed and fireproofing applied at lower levels.

Table 6.6 - Delivery Time For The Construction Of One Building Level

Existing Composite Steel System		Redesigned Concrete System	
Structural Element	Constr. Time (days)	Structural Element	Constr. Time (days)
W14 Columns	0.44	Column Formwork	6.26
Floor Members	3.62	Beam Formwork	10.63
18 gauge 2" floor deck	8.63	Column Rebar	4.85
3.5" LW concrete slab	2.25	Joist/Girder Rebar	27.66
Beam Fireproofing	11.47	Column placement	1.2
Column Fireproofing	2.19	Slab/Joist/Girder Placement	6.22
TOTAL CONSTR TIME	28.6	TOTAL CONSTR TIME	56.82

7. BREADTH #2: ACOUSTIC ANALYSIS

Noise pollution is a very relevant issue in the daily lives of all of us. With urban development causing buildings to be located closer and closer to many sources of noise, vibration and noise control factors must be taken into account when designing a building. Noise control is a particularly important design factor for the North Shore Equitable building due to the proposed transit line passing directly below the building. In addition to the transit line, the parking sublevel and the mechanical system on the roof could also prove to be sources of unwanted noise.

According to the *Pilot Survey of Subway and Bus Stop Noise Levels* published by the journal of urban health, the average noise level on a subway platform was measured as 86 ± 4 dBA. Noise levels occasionally exceeded 100 dB in this study as well. Due to the light rail transit line passing below the building, an acoustic breadth study was performed to ensure that this dB level is sufficiently decreased before it reaches the building interior. Shown below in Figure 7-1 is a section cut of the two subway tracks and their relation to the building foundation.

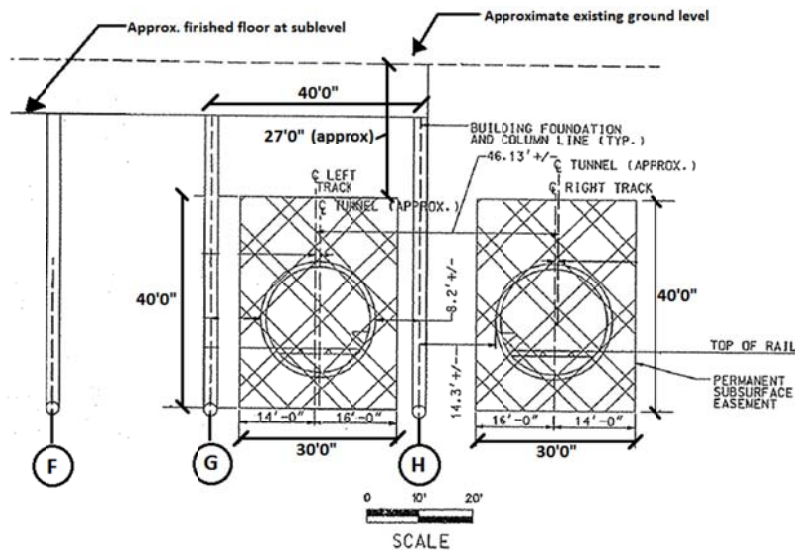

Figure 7-1: Subway Track Section Cut

Sound absorption coefficients and transmission loss values for various building materials were obtained from *Architectural Acoustics* by David Egan and *Building Acoustics and Vibration* by Osama A. B. Hassan. *Architectural Acoustics* by Marshall Long was referenced as well. For this analysis, the noise emitted by the light rail subway train was taken as 95 dB. Using both noise reduction coefficients and transmission loss coefficients, the perceived decibel level at both the parking sublevel and the first level were calculated. The highest perceived decibel level at the first level was found to be 19.7 dB at a 125 Hz frequency (as seen in Table 7.1). This is most likely due to the fact that trains and vehicle traffic typically emit noise at low frequencies. Given

the fact that this frequency is below the acceptable range for private and semi-private offices (38dB to 42 dB), the subway line should not be an issue as far as noise control is concerned. The noise emitted by cars in the parking sublevel was taken into account as well. As shown in Table 7.2, all perceived decibel levels at the first floor for passenger vehicles are below the acceptable range for private and semi-private offices (38dB to 42 dB). It should be noted that this calculation was performed using a decibel level emitted by cars cruising at 55 miles per hour. Obviously, in a parking garage, cars will not be traveling this fast and thus the calculated decibel levels at the first floor are highly conservative.

Table 7.1 - Redesigned System STL at Parking Sublevel

	Octave Band Frequency (Hz)						
	125	250	500	1000	2000	4000	dB
Light Rail Transit Train (dB)	102	94	90	86	87	83	95
dB reduction due to tunnel + soil	12.3	14.3	13.	14.7	15.1	15.1	13.
dB reduction due to S.O.G.	38	43	52	59	67	72	47
Perceived Noise at Parking	51.7	36.7	24.	12.3	4.9	0.0	34.
Redesigned System STL at Level 1							
dB reduction due parking level	32	30	32	38	45	49	38
Perceived Noise at Level 1	19.7	6.7	-7.4	-	-	-	-3.9

Table 7.2 - Redesigned System STL at Parking Sublevel

	Octave Band Frequency (Hz)						dBA
	125	250	500	1000	2000	4000	
Passenger car (at 55mph cruising speed)	70	67	66	67	66	59	71
dB reduction due parking level CMU walls	48	42	45	56	57	66	44
Perceived Noise at Level 1	22.0	25.0	21.0	11.0	9.0	-7.0	27.0

For this particular case, the propagation of ground borne vibrations may have a larger impact on the building design than actual noise transmission. Factors that must be taken into account with respect to vibrations include the path of the vibrations through the foundation into the structure, the type of foundation, and the composition of soil that is in direct contact with the foundation and the vibration source. Although these factors should be taken into consideration, the specifics of structural design with regards to vibration are beyond the scope of this thesis and will not be discussed in detail.

In addition to noise reduction impacts of the parking sublevel and first level, the design of the roof system was also investigated. A comparison of the new and existing roof systems can be seen in Figure 7-2 on the next page. Table 7.3 shows a comparison of the new and existing roof systems from a transmission loss standpoint (neglecting insulation and finishes). From this table, it can be seen that the 4.5" deep concrete slab in the new design will be more effective in reducing noise transmission than the existing roof deck.

Table 7.3 - Sound Transmission Loss at Roof Level

Roof material	Octave band frequency (Hz)						R _w
	125	250	500	1000	2000	4000	
20 gage galvanized roof deck	8	14	20	26	32	38	24
4.5" concrete slab	38	38	41	48	57	65	47
Improvement in noise reduction	30	24	21	22	25	27	23

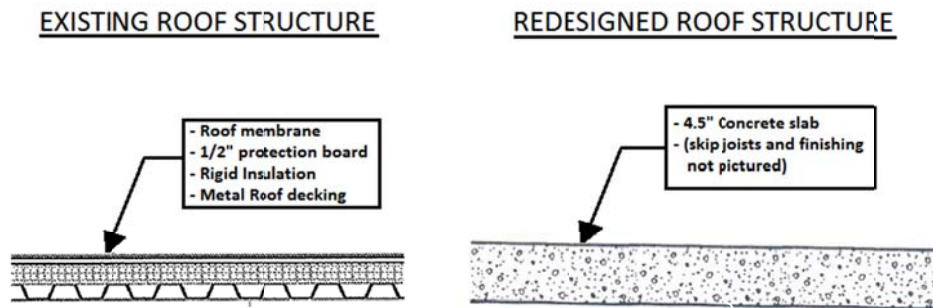

Figure 7-2: Existing and Redesigned Roof Structures

Based on all the calculations above, it can be seen that noise transmission due to the light rail transit line and the parking sublevel will not be an issue for the one way concrete joist and beam system. It can also be shown that the one way concrete joist design will improve noise control over the existing composite steel design. The redesigned floor system which includes a 4.5" normal weight concrete slab is both thicker and more dense than the 3.5" of lightweight concrete that is included as part of the existing floor system. This increase of the depth and density of the concrete will improve noise control in the new design. Furthermore, the increase in building weight and foundation size will improve the noise and vibration control as well. This is largely because a heavier structure will, as a rule, decrease vibration propagation. Also, the redesigned roof system will be more effective than the existing roof system at reducing noise from mechanical equipment. All these factors combined make the one way concrete joist and beam system more effective than the existing composite steel system at reducing noise transmission and vibrations.

8. CONCLUSIONS AND RECOMMENDATIONS

The purpose of this thesis was to redesign the North Shore Equitable Building using a one way concrete pan joist and beam system to reduce vibrations and improve noise control. After performing the structural redesign, several conclusions can be made about the new structure as compared with the original. The redesigned concrete system achieved all project goals it set out to meet. This system improved noise control, maintained the existing grid layout and even decreased project costs. Through the structural depth however, it was discovered that excessively large girder sizes are necessary to span the distances that steel wide flange beams easily handle. This created extra design challenges. The building weight also more than doubled, making the lateral design especially challenging. In addition to this, the increased weight had an adverse effect on the foundation, which had to be resized to compensate for the increased axial column loads. A decrease in building height due to decreased floor system thickness helped improve issues of building weight and cost to a certain degree but doesn't have a large enough impact to offset some of the negative results.



After completing a cost and scheduling analysis, the cost decreased by a small amount, but the construction time greatly increased. The acoustic study showed that a concrete system is in fact better than a composite steel system at improving noise control.



Even though this thesis met all its design goals, the results of this analysis must be put into perspective. When looking at the big picture, the issue of noise control will often take a back seat to larger issues such as building weight, ease of design and construction, project cost, and project delivery time. With the right acoustic finishes, the existing composite steel building could meet the same sound reduction performance that this redesigned system has met without all the extra building weight and construction time. This thesis has served to show that, even though the one way concrete system was successful from a project goal standpoint, a composite steel system is ultimately still the most practical and feasible design choice for a building such as this.

9. APPENDICES



Appendix A: Floor System Gravity Design Calculations

Excel Spreadsheet calculations for the floor system



Bay Type: 1		Design Parameters		Bay Type 1	
(// to joists) (x-axis)	40 ft	slab thickness:	4.5 in	Girder Type: 1	
(perp to joists) (y-axis)	44 ft	span size:	53 in	Interior Span	
Bay type:	exterior	span depth:	20 in		
Design Slab		rib width:	7 in	Wall Load =	0.9 k/ft
slab self weight =	56.25 psf	girder width:	40 in	Dead Load =	3.74 k/ft
joist/slab area =	2.847 ft ²	Column size:	40 in	Live Load =	1.60 k/ft
joist/slab self weight =	85.4167 psf	f'c =	4000 psi	w _u = 1.2DL + 1.6LL =	7.05 k/ft
girder self weight =	1020.83 lb/ft	Steel F _y =	60 ksi	M _{uA} ⁻ (interior) =	1060.42 ft.k
Dead Load =	0.07625 k/ft ²	conc weight =	150 pcf	M _{uB} ⁻ (interior) =	1060.42 ft.k
Live Load =	0.08 k/ft ²	SDL =	20 psf	M _u ⁺ (midspan) =	729.04 ft.k
w _u = 1.2DL + 1.6LL =	0.2195 k/ft ²	LL =	80 psf	depth =	22 in
Min reinf = .0018A _s =	0.0972 in ² /ft width	Design Pan Joists		Required top reinf =	12.05 in ²
Try #3 bars @ 12" spacing		Dead Load =	0.527 k/ft	Try 10 #10 top bars	A _s (in ²) = 12.7
Bar Area =	0.11 in ²	Live Load =	0.400 k/ft	Is A _s > A _{s,req} ?	YES, OK
Is A _s > A _{min} ?	yes, ok	w _u = 1.2DL + 1.6LL =	1.273 k/ft	# of bars =	10
l _n =	4.42 ft	l _n =	36.67	d _b =	1.27
Mu = w _u l _n ² /10 =	0.428 ft.k/ft width			a=A _s f _y /.85f' _c b =	5.60
a=A _s f _y /.85f' _c b =	0.162 in	M _{uA} ⁻ (exterior) =	71.28 ft.k	c = a/β ₁ =	6.59
φM _n = φA _s F _y (d-(a/2)) =	1.07371 ft.k	M _{uB} ⁻ (interior) =	171.08 ft.k	Does Tension Control?	YES, OK
Is φM _n > M _u ?	YES, OK	M _u ⁺ (midspan) =	122.20 ft.k	ε _t =	0.005 φ = 0.9
Required bot reinf =	1.92 in ²	Design reinforcement		Recalculated depth =	21.865 in
Try 1 #14 bottom bar	A _s (in ²) = 2.25	depth =	22.25 in	φM _n = φA _s F _y (d-(a/2)) =	1089.48 ft.k
Is A _s > A _{s,req} ?	YES, OK	Required top reinf =	1.37 in ²	Is φM _n > M _u ?	YES, OK
bar diameter =	1.27 in	Try 1 #11 top bar	A _s (in ²) = 1.56	Check bar spacing	OKAY
depth =	21.99 in	Is A _s > A _{s,req} ?	YES, OK	Required bot reinf =	8.28 in ²
67		ρ = A _s /bd =	0.0100	Try 9 #9 bot bars	A _s (in ²) = 9
B _{eff} =	79	a=A _s f _y /.85f' _c b =	3.933 in	Is A _s > A _{s,req} ?	YES, OK
117	67	c = a/β ₁ =	4.627 in	# of bars =	9
a=A _s f _y /.85f' _c b =	0.593 in	ε _s =(d-c)/c =	0.0114	d _b =	1
c = a/β ₁ =	0.697 in	Does Tension Control?	YES, OK	Check bar spacing	OKAY
ε _s =(d-c)/c =	0.0916	φM _n = φA _s F _y (d-(a/2)) =	142.39 ft.k	a=A _s f _y /.85f' _c b =	3.97
Does Tension Control?	YES, OK	Is φM _n > M _u ?	YES, OK	c = a/β ₁ =	4.67
φM _n = φA _s F _y (d-(a/2)) =	219.65 ft.k			Does Tension Control?	YES, OK
Is φM _n > M _u ?	YES, OK			Recalculated depth =	22.125 in
				φM _n = φA _s F _y (d-(a/2)) =	815.66 ft.k
				Is φM _n > M _u ?	YES, OK

Bay Type: 2			Design Parameters			Bay Type 2		
(// to joists) (x-axis)	40	ft	slab thickness:	4.5	in	Girder Type: 2		
(perp to joists) (y-axis)	42	ft	pan size:	53	in			
Bay type:	exterior		pan depth:	20	in	Exterior Span		
Design Slab			rib width:	7	in			
slab self weight =	56.25	psf	girder width:	32	in	Wall Load =	0	k/ft
joist/slab area =	2.847	ft ²	Column size:	20	in	Dead Load =	2.70	k/ft
joist/slab self weight =	85.416667	psf	$f'_c =$	4000	psi	Live Load =	1.60	k/ft
girder self weight =	816.66667	lb/ft	Steel $F_y =$	60	ksi	$w_u = 1.2DL + 1.6LL =$	5.80	k/ft
			conc weight =	150	pcf	M_{uA}^- (exterior) =	589.37	ft.k
Dead Load =	0.07625	k/ft ²	SDL =	20	psf	M_{uB}^- (interior) =	942.99	ft.k
Live Load =	0.08	k/ft ²	LL =	80	psf	M_u^+ (midspan) =	673.56	ft.k
$w_u = 1.2DL + 1.6LL =$	0.2195	k/ft ²	Design Pan Joists			depth =	22	in
			Dead Load =	0.527	k/ft	Required top reinf =	10.72	in ²
			Live Load =	0.400	k/ft	Try 9 #10 top bars	A_s (in ²) =	11.43
$w_u = 1.2DL + 1.6LL =$	0.2195	k/ft ²	$w_u = 1.2DL + 1.6LL =$	1.273	k/ft	Is $A_s > A_{s, req}$?	YES, OK	
Min reinf = $.0018A_g =$	0.0972	in ² /ft width	$I_n =$	37.33		# of bars =	9	
Try #3 bars @ 12" spacing						$d_o =$	1.27	
Bar Area =	0.11	in ²	M_{uA}^- (exterior) =	73.90	ft.k	$a = A_s f_y / .85 f'_c b =$	6.30	
Is $A_s > A_{min}$?	yes, ok		M_{uB}^- (interior) =	177.36	ft.k	$c = a / \beta_1 =$	7.42	
$I_n =$	4.42	ft	M_u^+ (midspan) =	126.68	ft.k	Does Tension Control?	YES, OK	
$M_u = w_u I_n^2 / 10 =$	0.428	ft.k/ft width	Design reinforcement			$\epsilon_t =$	0.005	$\phi = 0.9$
$a = A_s f_y / .85 f'_c b =$	0.162	in	depth =	22.25	in	Recalculated depth =	21.865	in
$\phi M_n = \phi A_s F_y (d - (a/2)) =$	1.0737132	ft.k	required top reinf =	1.42	in ²	$\phi M_n = \phi A_s F_y (d - (a/2)) =$	962.52093	ft.k
Is $\phi M_n > M_u$?	YES, OK		Try 1 #11 top bar	A_s (in ²) =	1.56	Is $\phi M_n > M_u$?	YES, OK	
Required bot reinf =	1.99	in ²	Is $A_s > A_{s, req}$?	YES, OK		Check bar spacing	OKAY	
Try 1 #14 bottom bar	A_s (in ²) =	2.25	$\rho = A_s / bd =$	0.0100		Required bot reinf =	7.65	in ²
Is $A_s > A_{s, req}$?	YES, OK		$a = A_s f_y / .85 f'_c b =$	3.933	in	Try 7 #10 bot bars	A_s (in ²) =	8.89
bar diameter =	1.27	in	$c = a / \beta_1 =$	4.627	in	Is $A_s > A_{s, req}$?	YES, OK	
depth =	21.99	in	$\epsilon_s = (d - c) / c =$	0.0114		# of bars =	7	
$B_{eff} =$	67		Does Tension Control?	YES, OK		$d_o =$	1.27	
	79	67	$M_n = \phi A_s F_y (d - (a/2)) =$	142.39	ft.k	Check bar spacing	OKAY	
	119		Is $\phi M_n > M_u$?	YES, OK		$a = A_s f_y / .85 f'_c b =$	4.90	
$a = A_s f_y / .85 f'_c b =$	0.593	in				$c = a / \beta_1 =$	5.77	
$c = a / \beta_1 =$	0.697	in				Does Tension Control?	YES, OK	
$\epsilon_s = (d - c) / c =$	0.0916					Recalculated depth =	21.99	in
Does Tension Control?	YES, OK					$\phi M_n = \phi A_s F_y (d - (a/2)) =$	781.65	ft.k
$\phi M_n = \phi A_s F_y (d - (a/2)) =$	219.65	ft.k				Is $\phi M_n > M_u$?	YES, OK	
Is $\phi M_n > M_u$?	YES, OK							



Bay Type: 3			Design Parameters			Bay Type 3		
(// to joists) (y-axis)	42	ft	slab thickness:	4.5	in	Girder Type: 3		
(perp to joists) (x-axis)	30	ft	pan size:	53	in			
Bay type:	interior		pan depth:	20	in	Interior Span		
Design Slab			rib width:	7	in			
slab self weight = 56.25 psf			girder width:	32	in			
joist/slab area = 2.847 ft²			Column size:	24	in			
joist/slab self weight = 85.416667 psf			f'c =	4000	psi	Wall Load = 0.9 k/ft		
girder self weight = 816.66667 lb/ft			Steel F _y =	60	ksi			
Dead Load = 0.07625 k/ft²			conc weight =	150	pcf	Live Load = 1.68 k/ft		
Live Load = 0.08 k/ft²			SDL =	20	psf			
w _u = 1.2DL + 1.6LL = 0.2195 k/ft²			LL =	80	psf	M _{uA} ⁺ (exterior) = 508.26 ft.k		
Min reinf = .0018A _s = 0.0972 in²/ft width			Design Pan Joists					
Try #3 bars @ 12" spacing			Dead Load = 0.527 k/ft			M _u ⁺ (midspan) = 349.43 ft.k		
Bar Area = 0.11 in²			Live Load = 0.400 k/ft					
Is A _s > A _{min} ? yes, ok			w _u = 1.2DL + 1.6LL = 1.273 k/ft			depth = 22 in		
I _n = 4.42 ft			I _n = 39.33					
Mu = w _u I _n ²/10 = 0.428 ft.k/ft width						Try 8 #8 top bars A _s (in²) = 6.32		
a = A _s f _y / .85f'c b = 0.162 in			M _{uA} ⁺ (exterior) = 82.03 ft.k					
øM _n = øA _s F _y (d-(a/2)) = 1.0737132 ft.k			M _{uB} ⁺ (interior) = 196.87 ft.k			# of bars = 8		
Is øM _n > M _u ? YES, OK			M _u ⁺ (midspan) = 140.62 ft.k					
Required bot reinf = 2.21 in²			Design reinforcement			a = A _s f _y / .85f'c b = 3.49		
Try 1 #14 bottom bar A _s (in²) = 2.25			depth = 22.25 in					
Is A _s > A _{s req} ? YES, OK			Required top reinf = 1.58 in²			Does Tension Control? YES, OK		
bar diameter = 1.27 in			Try 1 #14 top bar A _s (in²) = 2.25					
depth = 21.99 in			Is A _s > A _{s req} ? YES, OK			Recalculated depth = 22 in		
B _{eff} = 79 67			ρ = A _s /bd = 0.0144					
125			a = A _s f _y / .85f'c b = 5.672 in			Is øM _n > M _u ? YES, OK		
a = A _s f _y / .85f'c b = 0.593 in			c = a/β ₁ = 6.673 in					
c = a/β ₁ = 0.697 in			ε _s = (d-c)/c = 0.0070			Required bot reinf = 3.97 in²		
ε _s = (d-c)/c = 0.0916			Does Tension Control? YES, OK					
Does Tension Control? YES, OK			øM _n = øA _s F _y (d-(a/2)) = 196.57 ft.k			Is A _s > A _{s req} ? YES, OK		
øM _n = øA _s F _y (d-(a/2)) = 219.65 ft.k			Is øM _n > M _u ? YES, OK					
Is øM _n > M _u ? YES, OK						d _o = 1.00		
						a = A _s f _y / .85f'c b = 2.61		
						Does Tension Control? YES, OK		
						øM _n = øA _s F _y (d-(a/2)) = 444.05 ft.k		

Bay Type: 4			Design Parameters			Bay Type 4		
(// to joists) (y-axis)	44	ft	slab thickness:	4.5	in	Girder Type: 4		
(perp to joists) (x-axis)	30	ft	pan size:	53	in	Interior Span		
Bay type:	interior		pan depth:	20	in			
Design Slab			rib width:	7	in			
slab self weight =	56.25	psf	girder width:	32	in			
joist/slab area =	2.847	ft ²	Column size:	26	in			
joist/slab self weight =	85.41667	psf	f'c =	4000	psi			
girder self weight =	816.6667	lb/ft	Steel F _y =	60	ksi			
			conc weight =	150	pcf			
			SDL =	20	psf			
			LL =	80	psf			
Dead Load =	0.07625	k/ft ²	Design Pan Joists					
Live Load =	0.08	k/ft ²	Dead Load =	0.527	k/ft			
w _u = 1.2DL + 1.6LL =	0.2195	k/ft ²	Live Load =	0.400	k/ft			
			w _u = 1.2DL + 1.6LL =	1.273	k/ft			
Min reinf = .0018A _g =	0.0972	in ² /ft width	l _n =	39.33				
Try #3 bars @ 12" spacing								
Bar Area =	0.11	in ²	Dead Load =	0.527	k/ft			
Is A _s > A _{s,req} ?	yes, ok		Live Load =	0.400	k/ft			
l _n =	4.42	ft	w _u = 1.2DL + 1.6LL =	1.273	k/ft			
Mu = w _u l _n ² /10 =	0.428	ft.k/ft width	l _n =	39.33				
a = A _s f _y / .85f' _c b =	0.162	in	M _{uA} ⁺ (exterior) =	82.02	ft.k			
ϕM _n = ϕA _s F _y (d-(a/2)) =	1.073713	ft/k	M _{uB} ⁺ (interior) =	196.84	ft.k			
Is ϕM _n > M _u ?	YES, OK		M _u ⁺ (midspan) =	140.60	ft.k			
Required bot reinf =	2.21	in ²	Design reinforcement					
Try 1 #14 bottom bar	A _s (in ²) = 2.25		depth =	22.25	in			
Is A _s > A _{s,req} ?	YES, OK		Required top reinf =	1.58	in ²			
bar diameter =	1.27	in	Try 1 #14 top bar	A _s (in ²) = 2.25				
depth =	21.99	in	Is A _s > A _{s,req} ?	YES, OK				
	67		ρ = A _s /bd =	0.0144				
B _{eff} =	79	67	a = A _s f _y / .85f' _c b =	5.672	in			
	124.99		c = a/β ₁ =	6.673	in			
a = A _s f _y / .85f' _c b =	0.593	in	ε _s = (d-c)/c =	0.0070				
c = a/β ₁ =	0.697	in	Does Tension Control?	YES, OK				
ε _s = (d-c)/c =	0.0916		ϕM _n = ϕA _s F _y (d-(a/2)) =	196.57	ft.k			
Does Tension Control?	YES, OK		Is ϕM _n > M _u ?	YES, OK				
ϕM _n = ϕA _s F _y (d-(a/2)) =	219.65	ft/k						
Is ϕM _n > M _u ?	YES, OK							
						Does Tension Control? YES, OK		
						Recalculated depth = 22 in		
						ϕM _n = ϕA _s F _y (d-(a/2)) = 704.6611 ft.k		
						Is ϕM_n > M_u? YES, OK		
						Check bar spacing OKAY		
						Required bot reinf = 5.31 in ²		
						Try 7 #8 bot bars A _s (in ²) = 5.53		
						Is A _s > A _{s,req} ? YES, OK		
						# of bars = 7		
						d _b = 1		
						Check bar spacing OKAY		
						a = A _s f _y / .85f' _c b = 3.05		
						c = a/β ₁ = 3.59		
						Does Tension Control? YES, OK		
						Recalculated depth = 22.125 in		
						ϕM _n = ϕA _s F _y (d-(a/2)) = 512.64 ft.k		
						Is ϕM _n > M _u ? YES, OK		

Excel Spreadsheet calculations for the roof system

Bay Type: 1		Design Parameters		Bay Type 1	
(// to joists) (x-axis)	40 ft	slab thickness:	4.5 in	Girder Type: 1	
(perp to joists) (y-axis)	44 ft	pan size:	53 in	Interior Span	
Bay type:	exterior	pan depth:	16 in		
Design Slab		rib width:	7 in	Wall Load =	0 k/ft
slab self weight =	56.25 psf	girder width:	28 in	Dead Load =	2.40 k/ft
joist/slab area =	2.653 ft ²	Column size:	24 in	Live Load =	0.40 k/ft
joist/slab self weight =	79.5833 psf	f'c =	4000 psi	w _u = 1.2DL + 1.6LL =	3.52 k/ft
girder self weight =	597.917 lb/ft	Steel F _y =	60 ksi	M _u ⁺ (interior) =	565.23 ft.k
Dead Load =	0.07625 k/ft ²	conc weight =	150 pcf	M _u ⁻ (interior) =	565.23 ft.k
Live Load =	0.02 k/ft ²	SDL =	20 psf	M _u ⁺ (midspan) =	388.59 ft.k
w _u = 1.2DL + 1.6LL =	0.1235 k/ft ²	LL =	20 psf	depth =	18 in
Min reinf = .0018A _g =	0.0972 in ² /ft. width	Design Pan Joists		Required top reinf =	7.85 in ²
Try #3 bars @ 12" spacing		Deac Load =	0.498 k/ft	Try 11 #8 top bars	A _s (in ²) = 8.69
Bar Area =	0.11 in ²	Live Load =	0.100 k/ft	Is A _s > A _{s,req} ?	YES, OK
Is A _s > A _{s,min} ?	yes, ok	w _u = 1.2DL + 1.6LL =	0.758 k/ft	# of bars =	11
l _n =	4.42 ft	l _n =	37.67	d _o =	1.00
Mu = w _u l _n ² /10 =	0.241 ft.k/ft width			a = A _s f _y / .85f' _c b =	5.48
a = A _s f _y / .85f' _c b =	0.162 in	M _u ⁺ (exterior) =	44.78 ft.k	c = a/β ₁ =	6.44
φM _n = φA _s F _y (d-(a/2)) =	1.07371 ft.k	M _u ⁻ (interior) =	107.47 ft.k	Does Tension Control?	YES, OK
Is φM _n > M _u ?	YES, OK	M _u ⁺ (midspan) =	76.77 ft.k	ε _t =	0.005 φ = 0.9
Required bot reinf =	1.47 in ²	Design reinforcement		Recalculated depth =	18 in
Try 2 #8 bottom bars	A _s (in ²) = 1.58	depth =	18.25 in	φM _n = φA _s F _y (d-(a/2)) =	596.803 ft.k
Is A _s > A _{s,req} ?	YES, OK	Required top reinf =	1.05 in ²	Is φM _n > M _u ?	YES, OK
bar diameter =	1 in	Try 2 #8 top bars	A _s (in ²) = 1.58	Check bar spacing	NOT OKAY
depth =	18.125 in	Is A > A _{s,req} ?	YES, OK	Required bot reinf =	5.40 in ²
67		ρ = A _s /bd =	0.0124	Try 7 #8 bot bars	A _s (in ²) = 5.53
B _{eff} =	79	a = A _s f _y / .85f' _c b =	3.983 in	Is A _s > A _{s,req} ?	YES, OK
120		c = a/β ₁ =	4.686 in	# of bars =	7
a = A _s f _y / .85f' _c b =	0.416 in	ε _t = (d-c)/c =	0.0087	d _o =	1
c = a/β ₁ =	0.490 in	Does Tension Control?	YES, OK	Check bar spacing	OKAY
ε _t = (d-c)/c =	0.1081	φM _n = φA _s F _y (d-(a/2)) =	115.60 ft.k	a = A _s f _y / .85f' _c b =	3.49
Does Tension Control?	YES, OK	Is φM _n > M _u ?	YES, OK	c = a/β ₁ =	4.10
φM _n = φA _s F _y (d-(a/2)) =	127.39 ft.k			Does Tension Control?	YES, OK
Is φM _n > M _u ?	YES, OK			Recalculated depth =	18.125 in
				φM _n = φA _s F _y (d-(a/2)) =	407.67 ft.k
				Is φM _n > M _u ?	YES, OK



Spacing will work with a double layer of top reinforcement. The spreadsheet is only designed to check one layer.

Bay Type: 2		Design Parameters		Bay Type 1	
(// to joists) (x-axis)	40 ft	slab thickness:	4.5 in	Girder Type: 1	
(perp to joists) (y-axis)	42 ft	pan size:	53 in	Interior Span	
Bay type:	exterior	pan depth:	16 in		
Design Slab		rib width:	7 in	Wall Load = 0 k/ft	
slab self weight =	56.25 psf	girder width:	28 in	Dead Load = 2.40 k/ft	
joist/slab area =	2.653 ft ²	Column size:	24 in	Live Load = 0.40 k/ft	
joist/slab self weight =	79.583333 psf	$f'c =$	4000 psi	$w_u = 1.2DL + 1.6LL = 3.52$ k/ft	
girder self weight =	597.91667 lb/ft	Steel $F_y =$	60 ksi	M_u^+ (interior) = 565.23 ft.k	
		conc weight =	150 pcf	M_u^+ (interior) = 565.23 ft.k	
		SDL =	20 psf	M_u^+ (midspan) = 388.59 ft.k	
		LL =	20 psf	depth = 18 in	
Dead Load =	0.07625 k/ft ²	Design Pan Joists		Required top reinf = 7.85 in ²	
Live Load =	0.02 k/ft ²	Dead Load =	0.498 k/ft	Try 11 #8 top bars A_s (in ²) = 8.69	
$w_u = 1.2DL + 1.6LL =$	0.1295 k/ft ²	Live Load =	0.100 k/ft	Is $A_s > A_{s, req}$? YES, OK	
Min reinf = $.0018A_g =$	0.0972 in ² /ft width	$w_u = 1.2DL + 1.6LL =$	0.758 k/ft	# of bars = 11	
Try #3 bars @ 12" spacing		$I_n =$	37.67	$d_o = 1.00$	
Bar Area =	0.11 in ²			$a = A_s f_y / .85 f'c b = 5.48$	
Is $A_s > A_{s, min}$?	yes, ok	$M_{u, ext}$ (exterior) =	44.78 ft.k	$c = a / \beta_1 = 6.44$	
$I_n =$	4.42 ft	$M_{u, int}$ (interior) =	107.47 ft.k	Does Tension Control? YES, OK	
$M_u = w_u I_n^2 / 10 =$	0.241 ft.k/ft width	M_u^+ (midspan) =	76.77 ft.k	$\epsilon_t = 0.005 \quad \phi = 0.9$	
$a = A_s f_y / .85 f'c b =$	0.162 in	Design reinforcement		Recalculated depth = 18 in	
$\phi M_n = \phi A_s F_y (d - (a/2)) =$	1.0737132 ft/k	depth =	18.25 in	$\phi M_n = \phi A_s F_y (d - (a/2)) = 596.803$ ft.k	
Is $\phi M_n > M_u$?	YES, OK	required top reinf =	1.05 in ²	Is $\phi M_n > M_u$? YES, OK	
Required top reinf =	1.47 in ²	Try 2 #8 top bars A_s (in ²) =	1.58	Check bar spacing NCT OKAY	
Try 2 #8 bottom bars A_s (in ²) =	1.58	Is $A_s > A_{s, req}$?	YES, OK	Required bot reinf = 5.40 in ²	
Is $A_s > A_{s, req}$?	YES, OK	$p = A_s / bd =$	0.0124	Try 7 #8 bot bars A_s (in ²) = 5.53	
bar diameter =	1 in	$a = A_s f_y / .85 f'c b =$	3.983 in	Is $A_s > A_{s, req}$? YES, OK	
depth =	18.125 in	$c = a / \beta_1 =$	4.686 in	# of bars = 7	
$B_{eff} =$	79	$\epsilon_t = (d-c) / c =$	0.0087	$d_o = 1$	
$a = A_s f_y / .85 f'c b =$	0.416 in	Does Tension Control?	YES, OK	Check bar spacing OKAY	
$c = a / \beta_1 =$	0.490 in	$M_n = \phi A_s F_y (d - (a/2)) =$	115.60 ft.k	$a = A_s f_y / .85 f'c b = 3.49$	
$\epsilon_t = (d-c) / c =$	0.1081	Is $\phi M_n > M_u$?	YES, OK	$c = a / \beta_1 = 4.10$	
Does Tension Control?	YES, OK			Does Tension Control? YES, OK	
$\phi M_n = \phi A_s F_y (d - (a/2)) =$	127.39 ft/k			Recalculated depth = 18.125 in	
Is $\phi M_n > M_u$?	YES, OK			$\phi M_n = \phi A_s F_y (d - (a/2)) = 407.67$ ft.k	
				Is $\phi M_n > M_u$? YES, OK	

Spacing will work with a double layer of top reinforcement. The spreadsheet is only designed to check one layer.

Bay Type: 3			Design Parameters			Bay Type 3		
(// to joists) (y-axis)	42	ft	slab thickness:	4.5	in	Girder Type: 3		
(perp to joists) (x-axis)	30	ft	pan size:	53	in	Interior Span		
Bay type:	interior		pan depth:	16	in			
Design Slab			rib width:	7	in			
slab self weight = 56.25 psf			girder width:	24	in			
joist/slab area = 2.653 ft ²			Column size:	24	in			
joist/slab self weight = 79.583333 psf			f'c =	4000	psi			
girder self weight = 512.5 lb/ft			Steel F _y =	60	ksi			
Dead Load = 0.07625 k/ft ²			conc weight =	150	pcf			
Live Load = 0.02 k/ft ²			SDL =	20	psf			
w _u = 1.2DL + 1.6LL = 0.1235 k/ft ²			LL =	20	psf			
Min reinf = .0018A _s = 0.0972 in ² /ft width			Design Pan Joists					
Try #3 bars @ 12" spacing			Dead Load = 0.498 k/ft					
Bar Area = 0.11 in ²			Live Load = 0.100 k/ft					
Is A _s > A _{min} ? yes, ok			w _u = 1.2DL + 1.5LL = 0.758 k/ft					
l _n = 4.42 ft			I _n = 40.00					
Mu = w _u l _n ² /10 = 0.241 ft.k/ft width								
a = A _s f _y / .85f'c b = 0.162 in			M _{uA} (exterior) = 50.50 ft.k					
φM _n = φA _s F _y (d-(a/2)) = 1.0737132 ft/k			M _{uB} (interior) = 121.20 ft.k					
Is φM _n > M _u ? YES, OK			M _u ⁺ (midspan) = 86.57 ft.k					
Required top reinf = 1.66 in ²			Design reinforcement					
Try 2 #9 bottom bars A _s (in ²) = 2			depth = 18.25 in					
Is A _s > A _{s req} ? YES, OK			Required top reinf = 1.19 in ²					
bar diameter = 1.27 in			Try 2 #9 top bars A _s (in ²) = 2					
depth = 17.99 in			Is A _s > A _{s req} ? YES, OK					
67			ρ = A _s /bd = 0.0157					
B _{eff} = 79 67			a = A _s f _y / .85f'c b = 5.042 in					
a = A _s f _y / .85f'c b = 0.527 in			c = a/β ₁ = 5.932 in					
c = a/β ₁ = 0.620 in			ε _s = (d-c)/c = 0.0062					
ε _s = (d-c)/c = 0.0841			Does Tension Control? YES, OK					
Does Tension Control? YES, OK			φM _n = φA _s F _y (d-(a/2)) = 141.56 ft.k					
φM _n = φA _s F _y (d-(a/2)) = 159.54 ft/k			Is φM _n > M _u ? YES, OK					
Is φM _n > M _u ? YES, OK								
						Recalculated depth = 18 in		
						φM _n = φA _s F _y (d-(a/2)) = 346.76934 ft.k		
						Is φM _n > M _u ? YES, OK		
						Check bar spacing OKAY		
						Required bot reinf = 2.45 in ²		
						Try 4 #8 bot bars A _s (in ²) = 3.16		
						Is A _s > A _{s req} ? YES, OK		
						# of bars = 3		
						d _o = 1.00		
						Check bar spacing OKAY		
						a = A _s f _y / .85f'c b = 2.32		
						c = a/β ₁ = 2.73		
						Does Tension Control? YES, OK		
						Recalculated depth = 18.125 in		
						φM _n = φA _s F _y (d-(a/2)) = 241.22 ft.k		
						Is φM _n > M _u ? YES, OK		

*Please Note: The pan joist reinforcing has been adjusted to 1 #14 bar at both the top and bottom.

Bay Type: 4		Design Parameters		Bay Type 4	
(// to joists) (y-axis)	44 ft	slab thickness:	4.5 in	Girder Type: 4 Interior Span 	
(perp to joists) (x-axis)	30 ft	pan size:	53 in		
Bay type:	interior	pan depth:	16 in		
Design Slab		rib width:	7 in		
slab self weight =	56.25 psf	girder width:	24 in		
joist/slab area =	2.653 ft ²	Column size:	24 in		
joist/slab self weight =	79.58333 psf	f'c =	4000 psi		
girder self weight =	512.5 lb/ft	Steel F _y =	60 ksi		
Dead Load =	0.07625 k/ft ²	conc weight =	150 pcf		
Live Load =	0.02 k/ft ²	SDL =	20 psf		
w _u = 1.2DL + 1.6LL =	0.1235 k/ft ²	LL =	20 psf		
Design Pan Joists					
Dead Load =	0.498 k/ft	Dead Load =	0.498 k/ft	Wall Load = 0 k/ft Dead Load = 2.98 k/ft Live Load = 0.88 k/ft w _u = 1.2DL + 1.6LL = 4.99 k/ft M _{uA} ⁺ (exterior) = 355.58 ft.k M _{uB} ⁺ (interior) = 355.58 ft.k M _u ⁺ (midspan) = 244.46 ft.k depth = 18 in Required top reinf = 4.94 in ² Try 7 #8 top bars A _s (in ²) = 5.53	
Live Load =	0.100 k/ft	Live Load =	0.100 k/ft	Is A _s > A _{s, req} ? YES, OK # of bars = 7 d _b = 1.00 a = A _s f _y / .85f' _c b = 4.07 c = a / β ₁ = 4.78 Does Tension Control? YES, OK ε _s = 0.005 ϕ = 0.9	
w _u = 1.2DL + 1.6LL =	0.758 k/ft	w _u = 1.2DL + 1.6LL =	0.758 k/ft	Recalculated depth = 18 in ϕM _n = ϕA _s F _y (d - (a/2)) = 397.3366 ft.k Is ϕM _n > M _u ? YES, OK Check bar spacing OKAY	
Min reinf = .0018A _g =	0.0972 in ² /ft width	I _n =	42.00	Required bot reinf = 3.40 in ² Try 6 #8 bot bars A _s (in ²) = 4.74 Is A _s > A _{s, req} ? YES, OK # of bars = 6 d _b = 1 Check bar spacing OKAY	
Try #3 bars @ 12" spacing				Does Tension Control? YES, OK Recalculated depth = 18.125 in ϕM _n = ϕA _s F _y (d - (a/2)) = 349.44 ft.k Is ϕM _n > M _u ? YES, OK	
Bar Area =	0.11 in ²				
Is A _s > A _{s, min} ?	yes, ok				
I _n =	4.42 ft				
M _u = w _u l _n ² /10 =	0.241 ft.k/ft width				
a = A _s f _y / .85f' _c b =	0.162 in				
ϕM _n = ϕA _s F _y (d - (a/2)) =	1.073713 ft/k				
Is ϕM _n > M _u ?	YES, OK				
Required top reinf = 1.83 in ²		depth = 18.25 in			
Try 1 #14 bottom bar A _s (in ²) = 2.25		Required top reinf = 1.31 in ²			
Is A _s > A _{s, req} ? YES, OK		Try 2 #8 top bars A _s (in ²) = 1.58			
bar diameter = 1.69 in		Is A _s > A _{s, req} ? YES, OK			
depth = 17.78 in		ρ = A _s /bd = 0.0124			
B _{eff} = 67		a = A _s f _y / .85f' _c b = 3.983 in			
79		c = a / β ₁ = 4.686 in			
133		ε _s = (d - c) / c = 0.0087			
a = A _s f _y / .85f' _c b = 0.593 in		Does Tension Control? YES, OK			
c = a / β ₁ = 0.697 in		ϕM _n = ϕA _s F _y (d - (a/2)) = 115.60 ft.k			
ε _s = (d - c) / c = 0.0735		Is ϕM _n > M _u ? YES, OK			
Does Tension Control? YES, OK					
ϕM _n = ϕA _s F _y (d - (a/2)) = 177.02 ft/k					
Is ϕM _n > M _u ? YES, OK					

*Please Note: The pan joist reinforcing has been adjusted to 1 #14 bar at both the top and bottom.

Bay type 1 design check

Bar Type 1 Design check	Final Report	Page 1 of 6
<p style="writing-mode: vertical-rl; transform: rotate(180deg);">3-0235 — 50 SHEETS — 5 SQUARES 3-0236 — 100 SHEETS — 5 SQUARES 3-0237 — 200 SHEETS — 5 SQUARES 3-0137 — 200 SHEETS — FILLER</p> <p style="writing-mode: vertical-rl; transform: rotate(180deg);">COMET</p>	<p><u>Design Parameters</u></p> <p>Slab thickness: 4.5 inches Pan size = 53 in Pan depth = 20 in rib width = 7 in girder width = 40 in column size = 24 in</p> <p>$S_c = 4000 \text{ psi}$ $F_y(\text{steel}) = 60 \text{ ksi}$ conc = 150 psi MW SDL = 20 psf LL = 80 psf</p> <p>Slab self weight = $150 \left(\frac{4.5}{12} \right) = 56.25 \text{ psf}$</p> <p>Joist / slab Area = $60(4.5) + 20(7) = 410 \text{ in}^2 = 2.847 \text{ ft}^2$</p> <p>Joist / slab sw. = $2.847(150) = 427.05 \text{ lb/ft}$ $= 85.41 \text{ psf}$</p> <p>4.5 in Beam self weight = $\frac{(24.5)(40)(150)}{144} = 1020.83 \text{ lb/ft}$</p> <p><u>Floor Slab Design</u></p> <p>DL = 20 psf + 56.25 = 76.25 psf = .07625 k/ft²</p> <p>LL = 80 psf = .08 k/ft²</p> <p>$w_u = 1.2 \text{ DL} + 1.6 \text{ LL} = .2175 \text{ k/ft}^2$</p> <p>Analyze 12" section of slab: min reinf = $.0018 A_g = .0018(4.5)(12) = .0972 \text{ in}^2$ <small>Eq. 12.5.1</small></p> <p>Try #3 bars @ 12" spacing $\Rightarrow M_u = \frac{w_u l_n^2}{10} = \frac{.2175 \left(\frac{53}{12} \right)^2}{10} = .4282 \text{ ft-k/ft}$ <small>Eq. 12.5.2</small></p> <p>#3 bars: $A_s = 0.11 \text{ in}^2$</p> <p>$a = \frac{A_s C_y}{.85 f'_c b} = \frac{.11(60)}{.85(4)(12)} = .162 \text{ in}$</p> <p>$\phi M_n = .9(.11)(60) \left(2.25 - \frac{.162}{2} \right) = 12.88 \text{ in-k} = 1.073 \text{ ft-k}$</p> <p>$1.073 \text{ ft-k} > 0.439 \text{ ft-k} \checkmark \text{ ok}$</p> <div style="border: 1px solid black; padding: 5px; display: inline-block;"> <p>use #3 bars @ 12" spacing</p> </div>	

Bay, type Design check	Final Report	Page 2 of 6
---------------------------	--------------	-------------

Design An Joists

20" pan depth
53" pan size = 60" module

DL = 0.07625(5) = .3813 k/ft
rib size depth = (7)(20)(150pcf) $\left(\frac{8+2}{144 \times 12}\right)$
= 145.83 lb/ft = .1458 k/ft

Total DL = .3813 + .1458 = .5271 k/ft

Total LL = .08(5) = .4 k/ft

$w_u = 1.2DL + 1.6LL = 1.2(.5271) + 1.6(.4) = 1.273 \text{ k/ft}$

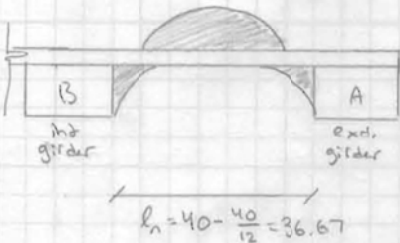

$M_{uA}^- = \frac{w_u l_n^2}{24} = \frac{1.273(36.67)^2}{24} = 71.32 \text{ ft-k}$

$M_{uB}^- = \frac{w_u l_n^2}{10} = \frac{1.273(36.67)^2}{10} = 171.18 \text{ ft-k}$

$M_{uA}^+ = \frac{w_u l_n^2}{14} = \frac{1.273(36.67)^2}{14} = 122.27 \text{ ft-k}$

Reinf. Depth = d = (70 + 4.5) - 2.25 = 22.25 in

$l_n = 40 - \frac{40}{12} = 36.67$

Top reinf

$A_s = \frac{M_u}{\phi d} = \frac{122.27}{4(22.25)} = 1.37 \text{ in}^2 \Rightarrow \text{Try } 2 \#9 \text{ bars}; A_s = 2 \text{ in}^2$

check if beam is tension controlled:

$\rho = \frac{A_s}{bd} = \frac{2}{7(22.25)} = .0128$ $a = \frac{A_s f_y}{.85 f_c b} = \frac{2(60)}{.85(4)(7)} = 5.042$

$c = \frac{a}{\beta_1} = \frac{5.042}{.85} = 5.932$ $\epsilon_s = \frac{d-c}{c} = \frac{22.25 - 5.932}{5.932} (.003) = .00825$

.00825 > .005 \Rightarrow Tension controlled

$\phi M_n = \phi A_s f_y \left(d - \frac{a}{2}\right) = .9(2)(60) \left(22.25 - \frac{5.042}{2}\right) = 177.56 \text{ ft-k}$

177.56 > 122.27 \checkmark ok

Use 2#9 Top bars

*Please Note: The reinforcing has been adjusted to 1 #14 top bar.

Bay TYPE 1 Design Check	Final Report	Page 3 of 6
----------------------------	--------------	-------------

Reinforce Bottom Bar

$$A_s = \frac{M_u}{\phi d} = \frac{171.08}{4(22.25)} = 1.92 \text{ in}^2 \quad \text{Try } 2 \# 10 \text{ bars: } A_s = 2.54 \text{ in}^2$$

Recalculated depth = $24.5 - 1.5 - .375 - \frac{1.27}{2} = 21.99 \text{ in}$

Treat as T beam:

$$b_{eff} = \min \begin{cases} b_w + \text{clear span} & 7 + 60 \\ b_w + 16h_f & 7 + 16(4.5) \\ b_w + l/4 & 7 + \frac{36.67(12)}{4} \end{cases}$$

$$b_{eff} = \min \begin{cases} 67 \\ 79 \\ 117 \end{cases} = 67 \text{ in}$$

$$a = \frac{A_s f_y}{.85 f'_c b} = \frac{2.54(60)}{.85(1)(67)} = .669 \quad c = \frac{a}{\beta_1} = \frac{.669}{.85} = .787$$

check that $a \leq h_g \Rightarrow .669 < 4.5 \checkmark \text{ ok}$

$$A_{s, min} = \frac{200 b_w d}{f_y} = \frac{200(7)(22)}{60000} = .513 < 2.54 \checkmark \text{ ok}$$

$$\epsilon_s = \frac{0.003}{.787} (22 - .787) = .081 > .005 \Rightarrow \text{tension controlled}$$

$$\phi M_n = \phi A_s f_y (d - \frac{a}{2}) = 0.9(2.54)(60)(22 - \frac{.669}{2}) = 247.63 \text{ ft-k}$$

$$247.63 \text{ ft-k} > 171.08 \text{ ft-k} \checkmark \text{ ok}$$

Use 2 # 10 bottom bars

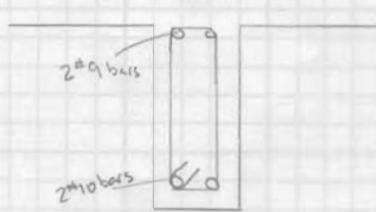

Shear design

$$V_u = \frac{w_u l_n}{2} = \frac{1.273(36.67)}{2} (1.15)$$

$$V_u = 26.84 \text{ k}$$

$$\phi V_c = \phi 2 \sqrt{f'_c} b_w d = 0.75(2) \frac{\sqrt{4000} (7)(22)}{1000} = 14.61 \text{ k}$$

$$\phi V_s = V_u - \phi V_c = 26.84 - 14.61 = 11.93 \text{ k}$$

$$\phi V_s = 11.93 = \frac{\phi A_s v f_y d}{S_{max}} \quad \text{where } S_{max} = \min \begin{cases} d/2 = \frac{22}{2} = 11 \\ 24 \end{cases} = 11$$

Rein spacing: $d/2 = \frac{22.25}{2} = 11.125 \Rightarrow \text{use } 8" \text{ spacing}$

Use #3 stirrups at 8" spacing

*Please Note: The reinforcing has been adjusted to 1 #14 bottom bar.

Bay Type 1 Design Check	Final Report	Page 4 of 6
<p>3-0235 — 50 SHEETS — 5 SQUARES 3-0236 — 100 SHEETS — 5 SQUARES 3-0237 — 200 SHEETS — 5 SQUARES 3-0137 — 200 SHEETS — FILLER</p> <p>COMET</p>	<p><u>check Girder bay 1 design</u></p> <p>wall load = 50 psf (18 ft) = 900 lb/ft = 0.9 k/ft</p> $DL = \left[20 \text{ psf} \left(\frac{40}{2} \right) + 85.41(16.67) + 1070.83 \text{ lb/ft} \right] \left(\frac{1}{1000} \right) + 0.9 \text{ k/ft}$ $DL = 2.845 + 0.9 = 3.745 \text{ k/ft}$ $LL = 80(20) = 1600 \text{ lb/ft} = 1.6 \text{ k/ft}$ $w_u = 1.2 DL + 1.6 LL = 1.2(3.745) + 1.6(1.6) = 7.054 \text{ k/ft}$ <p><u>ACI moment coefficients</u></p> $M_u^- = \frac{w_u l_n^2}{11} = \frac{7.054(40.67)^2}{11} = 1060.69 \text{ ft.k}$ $M_u^+ = \frac{w_u l_n^2}{16} = \frac{7.054(40.67)^2}{16} = 729.23 \text{ ft.k}$ <p><u>Top Reinforcement</u></p> $A_s = \frac{M_u}{\phi_b} = \frac{1060.69}{4(22)} = 12.05 \text{ in}^2 \quad \text{Try } 10^{\#} 10 \text{ bars? } A_s = 12.7 \text{ in}^2$ $a = \frac{A_s f_y}{.85 f_c' b} = \frac{12.7(60)}{.85(47)(40)} = 5.603 \quad c = \frac{a}{\beta_1} = 6.59$ <p>check that tension controls: $.375d = 8.25 > 6.59 \quad \checkmark \text{ ok}$</p> <p>$\therefore \epsilon_t = 0.005, \phi = 0.9$</p> $h_{\text{calculated depth}} = 24.5 - 1.5 - \frac{1.27}{2} - \frac{1}{2} = 21.87 \text{ in}$ $\phi M_n = \phi A_s f_y \left(d - \frac{a}{2} \right) = 0.9(12.7)(60) \left(21.87 - \frac{5.603}{2} \right) = 1089.76 \text{ ft.k}$ $1089.76 \text{ ft.k} > 1060 \text{ ft.k} \quad \checkmark \text{ ok}$ <p>check bar spacing: $10(1.27) + 9(2) + 2(2) = 34.7 < 40 \quad \checkmark \text{ ok}$</p> <div style="border: 1px solid black; padding: 5px; width: fit-content; margin: 10px auto;"> <p>use 10[#] 10 top bars</p> </div>	

Bay type 1 Design Check	Final Report	Page 5 of 6
----------------------------	--------------	-------------

Bottom Reinforcement

$$A_s = \frac{M_u}{4d} = \frac{729.23}{4(22)} = 8.287 \text{ in}^2 \quad \text{Try } 9\#9 \text{ bars: } A_s = 9 \text{ in}^2$$

check bar spacing: $2(2) + 9(1.128) + 2(8) = 30.152 < 40 \quad \checkmark \text{ ok}$

$$a = \frac{A_s f_y}{.85 f'_c b} = \frac{9(60)}{.85(4)(40)} = 3.97 \text{ in} \quad c = \frac{a}{\beta_1} = \frac{3.97}{.85} = 4.67 \text{ in}$$

check that tension controls: $.375d = 8.25 > 4.67 \quad \checkmark \text{ ok}$

Recalculated depth: $24.5 - 1.5 - (\frac{1.128}{2}) - .375 = 22.06 \text{ in}$

$$\phi M_n = \phi A_s F_y (d - \frac{a}{2}) = 0.9 (60)(9) (22.06 - \frac{3.97}{2}) = 813.08 \text{ ft}\cdot\text{k}$$

$813.08 \text{ ft}\cdot\text{k} > 729.23 \text{ ft}\cdot\text{k} \quad \checkmark \text{ ok}$

Use 9#9 bottom bars

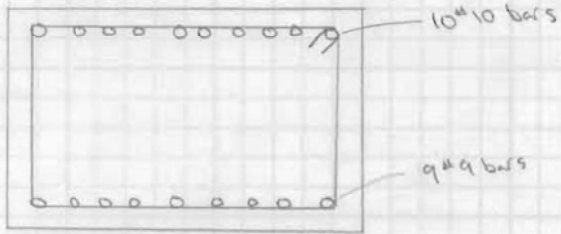

check I-gird deflections

$$\bar{y} = \frac{4.5(60)(22.25) + (7)(20)(10)}{4.5(60) + 7(20)} = 18.067 \text{ in}$$

$$I = \frac{bh^3}{12} + Ad^2 + \frac{bh^3}{12} + Ad^2$$

$$= \frac{60(4.5)^3}{12} + (4.5)(60)(22.25 - 18.067)^2 + \frac{7(20)^3}{12} + (7)(20)(10 - 18.067)^2 = 455.625 + 4724.32 + 4666.67 + 9110.71$$

$$I = 18957.33 \text{ in}^4$$

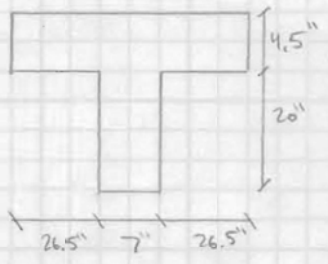
$$E = 33\sqrt{f'_c} (\omega_c)^{1.5} = 33\sqrt{4000} (150)^{1.5} = 3834 \text{ ksi}$$

	Bay Type 1 Design Check	Final Report	Page 6 of 6
3-0235 — 50 SHEETS — 5 SQUARES 3-0236 — 100 SHEETS — 5 SQUARES 3-0237 — 200 SHEETS — 5 SQUARES 3-0137 — 200 SHEETS — FILLER COMET	$w_{LL} = 80(5) = 400 \text{ lb/ft} = 0.4 \text{ k/ft} \quad w_{DL} = 0.527$ $w_{TL} = 0.4 + 0.527 = 0.927 \text{ k/ft}$ $\Delta_{LL} = \frac{5 w_{LL} l_n^4}{384 E I} = \frac{5(0.4)(40)^4(1728)}{384(3834)(18957.33)} = 0.317 \text{ in}$ $\frac{L}{360} = \frac{40(12)}{360} = 1.33 \text{ in} > 0.317 \text{ in} \quad \checkmark \text{ ok}$ $\Delta_{TL} = \frac{5(0.927)(40)^4(1728)}{384(3834)(18957.33)} = 0.735 \text{ in}$ $\frac{L}{240} = \frac{40(12)}{240} = 2 \text{ in} > 0.735 \text{ in} \quad \checkmark \text{ ok}$ <p><u>check Girder deflections</u></p> $\bar{y} = \frac{24.5}{2} = 12.25$ $I = \frac{bh^3}{12} = \frac{40(24.5)^3}{12} = 49020.42 \text{ in}^4 \quad E = 3834 \text{ ksi}$ $w_{LL} = 1.6 \text{ k/ft} \quad w_{DL} = 3.74 \text{ k/ft} \quad w_{TL} = 5.34 \text{ k/ft}$ $\Delta_{LL} = \frac{5 w_{LL} l_n^4}{384 E I} = \frac{5(1.6)(44)^4(1728)}{384(3834)(49020.42)} = 0.718 \text{ in}$ $\frac{L}{360} = \frac{44(12)}{360} = 1.47 \text{ in} > 0.718 \text{ in} \quad \checkmark \text{ ok}$ $\Delta_{TL} = \frac{5(5.34)(44 \cdot \frac{24}{12})^4(1728)}{384(3834)(49020.42)} = 1.99 \text{ in}$ $\frac{L}{240} = \frac{44(12)}{240} = 2.2 > 1.99 \quad \checkmark \text{ ok}$		

Stairwell girder framing design checks

Elevator core beam check	Final Report	Page 1 of 6
-----------------------------	--------------	-------------

3-0235 — 50 SHEETS — 5 SQUARES
3-0236 — 100 SHEETS — 5 SQUARES
3-0237 — 200 SHEETS — 5 SQUARES
3-0137 — 200 SHEETS — FILLER

COMET

- Stairwell well consists of 8" CMU wall
- Solve for Beams running along grid line D and E

Slab self weight = 56.25 psf
S.D.L = 20 psf
8" CMU wall weight = 91 psf = 1259 lb/ft
Live Load = 80 psf

Dead Load
= 56.25 psf (2.5 m) + 20(2.5) + 1259 lb/ft = 1449.63 lb/ft = 1.45 k/ft

Live Load
= 80 psf (2.5') + 100 psf (15x15.5/44) = 200 + 528.4 = 728.4 lb/ft = 728 k/ft

$w_u = 1.2D + 1.6L = 1.2(1.45) + 1.6(728) = 2.905 k/ft$

ACI moment coefficients: $\frac{w_u \ell_n^2}{11}$ (negative) and $\frac{w_u \ell_n^2}{16}$ (positive)
(chapter 8.3)

$M_u = \frac{2.905(44 - \frac{20}{12})^2}{11} = 473.28 ft-k$ $\frac{w_u \ell_n^2}{16} = \frac{2.905(44 - \frac{20}{12})^2}{16} = 325.38 ft-k$

Try 24x24.5 Beam

$A_{s, req} = \frac{M_u}{\phi d} = \frac{473.28}{4(22)} = 5.38 in^2$

Try 8#8 bars: $A_s = 6.32 in^2$

$a = \frac{A_s f_y}{.85 f_c b} = \frac{6.32(60)}{.85(4)(24)} = 4.65 in$ $c = \frac{a}{\beta_1} = \frac{4.65}{0.85} = 5.47 in$

Check slab dimension controls: $c < .375d = .375(22) = 8.25 > 5.47$ ✓ OK

$\phi = 0.9, \epsilon_t = 0.005$

$\phi A_n = \phi A_s f_y (d - \frac{a}{2}) = 0.9(6.32)(60)(22 - \frac{4.65}{2}) = 6714.68 ft-k = 559.55 ft-k$

559.55 > 473.28 ✓ OK

Elevator core beam check	Final Report	Page 2 of 6
-----------------------------	--------------	-------------

check bar spacing: $2(2) + 7(1) + 8(1.00) = 19 \text{ in} < 24 \text{ in} \checkmark \text{ok}$

Use 8#8 top bars

Bottom Reinforcement

$$A_s, \text{req} = \frac{M_u}{4d} = \frac{325.38}{4(22)} = 3.70 \text{ in}^2 \quad \text{Try } 5\#8 \text{ bars: } A_s = 3.95 \text{ in}^2$$

$$a = \frac{A_s f_y}{85 b \rho} = \frac{3.95(60)}{85(4)(22)} = 3.17 \text{ in} \quad c = \frac{a}{\beta_1} = \frac{3.17}{0.85} = 3.73$$

check strain controls: $c < .375d \Rightarrow .375d = 8.25 > 3.73 \checkmark \text{ok}$
 $\therefore \epsilon_t = 0.005, \phi = 0.9$

$$\phi M_n = \phi A_s f_y \left(d - \frac{a}{2} \right) = 0.9(3.95)(60) \left(22 - \frac{3.17}{2} \right) = 4354.5 \text{ in}\cdot\text{k} = 362.88 \text{ ft}\cdot\text{k}$$

$362.88 \text{ ft}\cdot\text{k} > 325.38 \text{ ft}\cdot\text{k} \checkmark \text{ok}$

Bar spacing ok because $5\#8 \text{ bars} < 8\#8 \text{ bars}$

Use 5#8 bottom bars

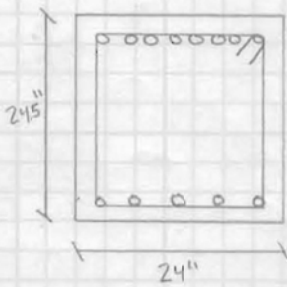

check deflections

$$\bar{y} = \frac{24.5}{2} = 12.25 \text{ in}$$

$$I = \frac{bh^3}{12} = \frac{24(24.5)^3}{12} = 29412.25 \text{ in}^4$$

$$E = 3834$$

$$w_{DL} = 1.45 \text{ k/ft} \quad w_{LL} = 0.728 \text{ k/ft} \quad w_{TL} = 2.178 \text{ k/ft}$$

$$\Delta_{LL} = \frac{5w_{LL}L_n^4}{384EI} = \frac{5(0.728)(44)^4(1728)}{384(3834)(29412.25)} = 0.54 \text{ in}$$

$L/360 = \frac{44(12)}{360} = 1.46 \text{ in} > 0.54 \text{ in} \checkmark \text{ok}$

$$\Delta_{TL} = \frac{5w_{TL}L_n^4}{384EI} = \frac{5(2.178)(44)^4(1728)}{384(3834)(29412.25)} = 1.63 \text{ in}$$

$L/240 = \frac{44(12)}{240} = 2.2 \text{ in} > 1.63 \text{ in} \checkmark \text{ok}$

Final Report Page 3 of 6

Stairwell Framing
girder design checks

Design Girder G1

Stairwell = 10 psf partition load
 Stairwell wall load = 10(13' height) = 130 lb/ft
 Joist slab sw = 85.41 psf
 Beam self weight (assume 24.5" x 20") = 510.42 lb/ft
 S.O.L = 70 psf
 LL = 80 psf
 Stairwell DL = 30 psf
 Stairwell LL = 100 psf

Dead Load:
 $20 \text{ psf} \left(\frac{33'}{2}\right) + 30 \text{ psf} \left(\frac{9'}{2}\right) + 85.41 \left(\frac{33'}{2}\right) + 510.42 \text{ lb/ft} + 130 \text{ lb/ft} = 2.51 \text{ k/ft}$

Live Load:
 $80 \text{ psf} \left(\frac{33'}{2}\right) + 100 \text{ psf} \left(\frac{9'}{2}\right) = 1770 = 1.77 \text{ k/ft}$

$W_u = 1.2 \text{ DL} + 1.6 \text{ LL} = 1.2(2.51) + 1.6(1.77) = 5.84 \text{ k/ft}$

ACI moment coefficients: $\frac{W_u l_n^2}{11} = \frac{5.84(20)^2}{11} = 212.36 \text{ ft}\cdot\text{k}$
 $\frac{W_u l_n^2}{16} = \frac{5.84(20)^2}{16} = 146 \text{ k/ft}$

Size top reinforcement
 $A_s, \text{top} = \frac{M_u}{4d} = \frac{212.36}{4(22)} = 2.41 \text{ in}^2$

Try 6#6 bars: $A_s = 2.64 \text{ in}^2$

$q = \frac{A_s f_y}{.85 f'_c b} = \frac{2.64(60)}{.85(14)(20)} = 2.33 \text{ in}$ $c = \frac{q}{8} = \frac{2.33}{8} = 2.74$

check design condn: $c < .375d = .375(22) = 8.25 > 2.74 \quad \checkmark \text{ ok}$

$\phi = 0.9, \quad \epsilon_t = 0.005$

$\phi M_n = \phi A_s f_y \left(d - \frac{a}{2}\right) = 0.9(2.64)(60) \left(22 - \frac{2.33}{2}\right) = 247.51 \text{ ft}\cdot\text{k}$
 $247.51 \text{ ft}\cdot\text{k} > 212.36 \text{ ft}\cdot\text{k} \quad \checkmark \text{ ok}$

check bar spacing: $2(2) + 2(5) + 6(.75) = 18.5 < 20 \quad \checkmark \text{ ok}$

Use 6#6 top bars

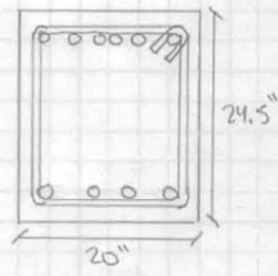
Stairwell framing girder design checks	Final Report	Page 4 of 6
<p>3-0235 — 5 SQUARES 3-0236 — 5 SQUARES 3-0237 — 5 SQUARES 3-0137 — FILLER</p> <p>50 SHEETS — 100 SHEETS — 200 SHEETS — 200 SHEETS —</p> <p>COMET</p>	<p>Bottom reinf.</p> $A_s, req = \frac{M_u}{4d} = \frac{146}{4(22)} = 1.66 \text{ in}^2$ <p>Try 4 #6 bars: $A_s = 1.76 \text{ in}^2$</p> $a = \frac{A_s f_y}{85 f_c' b} = \frac{1.76(60)}{85(4)(22)} = 1.41 \text{ in}$ $c = \frac{a}{\beta_1} = 1.66 \text{ in}$ <p>check the design controls: $c < .375d = 8.25 > 1.66 \checkmark \text{ ok}$</p> $\phi M_n = \phi A_s f_y \left(d - \frac{a}{2} \right) = .9(1.76)(60) \left(22 - \frac{1.41}{2} \right) = 168.65 \text{ ft}\cdot\text{k}$ <p>$168.65 \text{ ft}\cdot\text{k} > 146 \text{ ft}\cdot\text{k} \checkmark \text{ ok}$ Bar spacing: ok by inspection</p> <div style="border: 1px solid black; padding: 5px; width: fit-content; margin: 10px auto;"> <p>use 4 #6 bottom bars</p> </div>  <p>check deflection</p> $\bar{y} = \frac{24.5}{2} = 12.25 \text{ in}$ $I = \frac{b^3}{12} = \frac{20(24.5)^3}{12} = 24510 \text{ in}^4$ <p>$E = 3834 \text{ ksi}$</p> $w_{DL} = 2.51 \text{ k/ft} \quad w_{LL} = 1.77 \text{ k/ft} \quad w_{TL} = 4.28 \text{ k/ft}$ $\Delta_{LL} = \frac{5w_{LL}l_n^4}{384EI} = \frac{5(1.77)(20)^4(1728)}{384(3834)(24510)} = .068 \text{ in}$ $L/360 = \frac{20(12)}{360} = \frac{360}{360} = 1 \text{ in} > .068 \text{ in} \checkmark \text{ ok}$ <p>By inspection, Δ_{TL} is acceptable as well</p>	

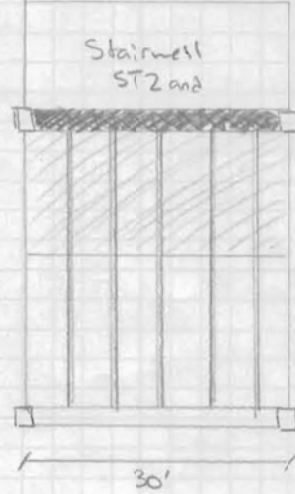
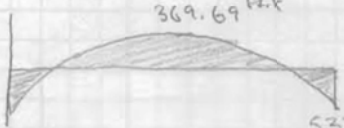
Stairwell framing girder design check	Final Report	Page 5 of 6
<p>3-0235 — 50 SHEETS — 5 SQUARES 3-0236 — 100 SHEETS — 5 SQUARES 3-0237 — 200 SHEETS — 5 SQUARES 3-0137 — 200 SHEETS — FILLER</p> <p>COMET</p> 	<p>Stairwell = 10 psf Partition wall Stairwell wall load = 10 psf (13.83' height) = 140 lb/ft</p> <p>3.84' Joist/Slab s.w. = 85.41 psf</p> <p>Beam self weight (assume 32" x 24.5" dimensions) = 816.67 lb/ft</p> <p>S.D.L. = 20 psf, Stairwell DL = 30 psf</p> <p><u>Dead Load</u></p> <p>slab area-beam area</p> $= 20 \text{ psf}(22') + 30 \text{ psf}(3.84') + 85.41 \left(22 - \frac{16}{12}\right) + 816.67 \frac{0}{12} + 140 \text{ lb/ft}$ $= 440 + 115.2 + 1765.14 + 816.67 + 140 = \boxed{3.28 \text{ k/ft}}$ <p><u>Live Load</u>: Floor LL = 80 psf Stairwell LL = 100 psf</p> <p>* no LL reduction allowed for one-way systems</p> $LL = 80 \text{ psf}(22) + 100 \text{ psf}(3.84) = 2.144 \text{ k/ft}$ $w_u = 1.2 DL + 1.6 LL = 1.2(3.28) + 1.6(2.144) = \boxed{7.37 \text{ k/ft}}$ <p>A/C Moment coefficients: $\frac{w_u l_n^2}{11}$ (negative) and $\frac{w_u l_n^2}{16}$ (positive)</p> <p>(chapter 8.3)</p> $M_u = \frac{w_u l_n^2}{11} = \frac{7.37(30 - \frac{20}{12})^2}{11} = 537.86 \text{ ft.k}$ $\frac{w_u l_n^2}{16} = \frac{7.37(28.33)^2}{16} = 369.69 \text{ ft.k}$  <p><u>Size top reinforcement</u></p> $A_{s,top} = \frac{M_u}{\phi d} = \frac{537.86}{4(22)} = 6.11 \text{ in}^2$ <p>Try 8#8 top bars: $A_s = 6.32 \text{ in}^2$</p> $a = \frac{A_s f_y}{.85 f'_c b} = \frac{6.32(60)}{.85(4)(32)} = 3.49 \text{ in}$ $c = \frac{a}{\beta_1} = \frac{3.49}{.85} = 4.11$ <p>check slab tension controls: $c < .375d \Rightarrow .375d = 8.25 > 4.11 \checkmark \text{ ok}$</p> $\phi = 0.9, \epsilon_t = 0.005$ $\phi M_n = \phi A_s f_y \left(d - \frac{a}{2}\right) = 0.9(6.32)(60) \left(22 - \frac{3.49}{2}\right) = 6912.6 \text{ in.k} = 576.05 \text{ ft.k}$ $\boxed{576.05 > 537.86 \checkmark \text{ ok}}$ <p>check bar spacing: $2(2) + 7(1) + 8(1.00) = 19 \text{ in} < 32 \text{ in} \checkmark \text{ ok}$</p> <p><u>Use 8#8 top bars</u></p>	

Stairwell framing girder design check	Final Report	Page 6 of 6
--	--------------	-------------

Bottom reinforcement

$A_{s, req} = \frac{M_u}{4d} = \frac{369.69}{4(22)} = 4.20 \text{ in}^2$ Try 6 #8 bottom bars: $A_s = 4.74 \text{ in}^2$

$a = \frac{A_s f_y}{.85 f_c b} = \frac{4.2(60)}{.85(4)(32)} = 2.316 \text{ in}$ $c = \frac{a}{\beta_1} = \frac{2.316}{.85} = 2.72 \text{ in}$

check that tension controls: $c < .375d \Rightarrow .375d = 8.25 > 2.72 \checkmark \text{ ok}$

$\therefore \epsilon_t = 0.05, \phi = 0.9$

$\phi M_n = \phi A_s f_y (d - \frac{a}{2}) = 0.9(4.74)(60)(22 - \frac{2.32}{2}) = 444.52 \text{ ft}\cdot\text{k}$

$444.52 > 369.69 \text{ ft}\cdot\text{k} \checkmark \text{ ok}$

check bar spacing: by inspection, if 8# bars work for top, 6# will work for bottom

use 6#8 bottom bars

check deflection

$\bar{\gamma} = \frac{24.5}{2} = 12.25 \text{ in}$

$I = \frac{b^3}{12} = \frac{32(245^3)}{12} = 39216.3 \text{ in}^4$

$E = 33750 (\omega_c)^{1.5} = 3375000 (150)^{1.5} = 3834 \text{ ksi}$

$w_{DL} = 3.28 \text{ k/ft}$ $w_{LL} = 2.144 \text{ k/ft}$ $w_{TL} = 5.424 \text{ k/ft}$

$\Delta_{LL} = \frac{5 w_{LL} l_n^4}{384 EI} = \frac{5(2.144)(30)^4(1728)}{384(3834)(39216.3)} = .259 \text{ in}$

$L/360 = \frac{30(12)}{360} = 1.00 > .259 \checkmark \text{ ok}$

$\Delta_{TL} = \frac{5 w_{TL} l_n^4}{384 EI} = \frac{5(5.424)(30)^4(1728)}{384(3834)(39216.3)} = 0.657 \text{ in}$

$L/240 = \frac{30(12)}{240} = 1.5 > 0.657 \checkmark \text{ ok}$

Appendix B: Column Gravity Design Calculations

Column design spreadsheet

Level 6															
Column	Total Area	Superimposed	Slab/joist DL	Beam DL	Column DL	Floor System DL	Ext. Wall DL	Roof DL	Total DL	LL Reduc.	Roof LL	Total LL	Roof SL	Pu	Mu
	(Ft ²)	Kips/Floor	Kips/Floor	Kips/Floor	Kips (est.)	Kips/Floor	Kips/Floor	Kips	Kips		Kips	Kips	Kips	Kips	Ft-K
1A & 4A	399	7.98	29.75	15.52	0.00	53.25	0.00	7.98	7.98	1.000	7.98	7.98	8.38	26.53	166.96
1B & 4B	714	14.28	53.24	27.77	0.00	95.29	0.00	14.28	14.28	0.531	7.58	7.57812	14.99	36.76	204.22
1C & 4C	630	12.60	46.98	24.50	0.00	84.08	0.00	12.6	12.6	0.549	29.39	29.3886	13.23	68.76	107.36
1D & 4D	630	12.60	46.98	24.50	0.00	84.08	0.00	12.6	12.6	0.549	29.39	29.3886	13.23	68.76	103.83
1E & 4E	630	12.60	46.98	24.50	0.00	84.08	0.00	12.6	12.6	0.549	29.39	29.3886	13.23	68.76	103.83
1F & 4F	630	12.60	46.98	24.50	0.00	84.08	0.00	12.6	12.6	0.549	29.39	29.3886	13.23	68.76	107.47
1G & 4G	735	14.70	54.81	28.58	0.00	98.09	0.00	14.7	14.7	0.527	7.74	7.74163	15.44	37.74	204.22
1H & 4H	420	8.40	31.32	16.33	0.00	56.05	0.00	8.4	8.4	0.616	5.17	5.17409	8.82	22.77	170.47
2A & 3A	817	16.34	65.46	15.52	0.00	97.32	0.00	16.34	16.34	0.512	8.37	8.37248	17.16	41.58	119.51
2B & 3B	1462	29.24	117.14	27.77	0.00	174.14	0.00	29.24	29.24	0.446	13.05	13.0454	30.70	71.31	14.83
2C & 3C	1290	25.80	103.36	24.50	0.00	153.66	0.00	25.8	25.8	0.459	50.31	50.3093	27.09	125.00	10.00
2D & 3D	1290	25.80	103.36	24.50	0.00	153.66	0.00	25.8	25.8	0.459	50.31	50.3093	27.09	125.00	9.35
2E & 3E	1290	25.80	103.36	24.50	0.00	153.66	0.00	25.8	25.8	0.459	50.31	50.3093	27.09	125.00	9.35
2F & 3F	1290	25.80	103.36	24.50	0.00	153.66	0.00	25.8	25.8	0.459	50.31	50.3093	27.09	125.00	10.00
2G & 3G	1505	30.10	120.58	28.58	0.00	179.27	0.00	30.1	30.1	0.443	13.34	13.3441	31.61	73.27	15.08
2H & 3H	860	17.20	68.90	16.33	0.00	102.44	0.00	17.2	17.2	0.506	8.70	8.69886	18.06	43.59	132.22
Level 5															
Column	Total Area	Superimposed	Slab/joist DL	Beam DL	Column DL	Floor System DL	Ext. Wall DL	Roof DL	Total DL	LL Reduc.	Roof LL	Total LL	Roof SL	Pu	Mu
	(Ft ²)	Kips/Floor	Kips/Floor	Kips/Floor	Kips (est.)	Kips/Floor	Kips/Floor	Kips	Kips		Kips	Kips	Kips	Kips	Ft-K
1A & 4A	399	7.98	29.75	15.52	24.75	53.25	27.50	7.98	113.48	1.000	7.98	39.90	8.38	204.21	100.49
1B & 4B	714	14.28	53.24	27.77	16.50	95.29	23.38	14.28	149.45	0.531	7.58	37.89	14.99	247.46	104.64
1C & 4C	630	12.60	46.98	24.50	16.50	84.08	20.63	12.6	133.81	0.549	29.39	57.05	13.23	258.46	51.35
1D & 4D	630	12.60	46.98	24.50	16.50	84.08	20.63	12.6	133.81	0.549	29.39	57.05	13.23	258.46	50.93
1E & 4E	630	12.60	46.98	24.50	16.50	84.08	20.63	12.6	133.81	0.549	29.39	57.05	13.23	258.46	50.93
1F & 4F	630	12.60	46.98	24.50	16.50	84.08	20.63	12.6	133.81	0.549	29.39	57.05	13.23	258.46	51.36
1G & 4G	735	14.70	54.81	28.58	16.50	98.09	24.06	14.7	153.36	0.527	7.74	38.71	15.44	253.68	104.64
1H & 4H	420	8.40	31.32	16.33	24.75	56.05	28.19	8.4	117.39	0.616	5.17	25.87	8.82	186.67	102.21
2A & 3A	817	16.34	65.46	15.52	16.50	97.32	22.00	16.34	152.16	0.512	8.37	41.86	17.16	258.14	62.68
2B & 3B	1462	29.24	117.14	27.77	5.73	174.14	0.00	29.24	209.11	0.446	13.05	65.23	30.70	370.65	11.08
2C & 3C	1290	25.80	103.36	24.50	5.73	153.66	0.00	25.8	185.19	0.459	50.31	97.66	27.09	392.02	4.33
2D & 3D	1290	25.80	103.36	24.50	5.73	153.66	0.00	25.8	185.19	0.459	50.31	97.66	27.09	392.02	4.24
2E & 3E	1290	25.80	103.36	24.50	5.73	153.66	0.00	25.8	185.19	0.459	50.31	97.66	27.09	392.02	4.24
2F & 3F	1290	25.80	103.36	24.50	5.73	153.66	0.00	25.8	185.19	0.459	50.31	97.66	27.09	392.02	4.34
2G & 3G	1505	30.10	120.58	28.58	5.73	179.27	0.00	30.1	215.09	0.443	13.34	66.72	31.61	380.67	11.08
2H & 3H	860	17.20	68.90	16.33	16.50	102.44	22.00	17.2	158.14	0.506	8.70	43.49	18.06	268.39	68.93
Level 4															
Column	Total Area	Superimposed	Slab/joist DL	Beam DL	Column DL	Floor System DL	Ext. Wall DL	Roof DL	Total DL	LL Reduc.	Roof LL	Total LL	Roof SL	Pu	Mu
	(Ft ²)	Kips/Floor	Kips/Floor	Kips/Floor	Kips (est.)	Kips/Floor	Kips/Floor	Kips	Kips		Kips	Kips	Kips	Kips	Ft-K
1A & 4A	399	7.98	29.75	15.52	49.64	53.25	55.16	7.98	219.29	1.000	7.98	71.82	8.38	382.25	112.24
1B & 4B	714	14.28	53.24	27.77	33.10	95.29	46.89	14.28	284.85	0.448	7.58	58.81	14.99	443.41	120.20
1C & 4C	630	12.60	46.98	24.50	33.10	84.08	41.37	12.6	255.23	0.461	29.39	75.89	13.23	434.31	60.15
1D & 4D	630	12.60	46.98	24.50	33.10	84.08	41.37	12.6	255.23	0.461	29.39	75.89	13.23	434.31	59.25
1E & 4E	630	12.60	46.98	24.50	33.10	84.08	41.37	12.6	255.23	0.461	29.39	75.89	13.23	434.31	59.25
1F & 4F	630	12.60	46.98	24.50	33.10	84.08	41.37	12.6	255.23	0.461	29.39	75.89	13.23	434.31	60.15
1G & 4G	735	14.70	54.81	28.58	33.10	98.09	48.27	14.7	292.25	0.446	7.74	60.15	15.44	454.65	120.20
1H & 4H	420	8.40	31.32	16.33	49.64	56.05	56.54	8.4	226.69	0.509	5.17	39.36	8.82	339.42	114.23
2A & 3A	817	16.34	65.46	15.52	33.10	97.32	44.13	16.34	288.19	0.436	8.37	65.31	17.16	458.90	72.36
2B & 3B	1462	29.24	117.14	27.77	11.49	174.14	0.00	29.24	389.02	0.400	13.05	106.61	30.70	652.75	11.64
2C & 3C	1290	25.80	103.36	24.50	11.49	153.66	0.00	25.8	344.60	0.400	50.31	132.87	27.09	639.66	4.66
2D & 3D	1290	25.80	103.36	24.50	11.49	153.66	0.00	25.8	344.60	0.400	50.31	132.87	27.09	639.66	4.57
2E & 3E	1290	25.80	103.36	24.50	11.49	153.66	0.00	25.8	344.60	0.400	50.31	132.87	27.09	639.66	4.57
2F & 3F	1290	25.80	103.36	24.50	11.49	153.66	0.00	25.8	344.60	0.400	50.31	132.87	27.09	639.66	4.66
2G & 3G	1505	30.10	120.58	28.58	11.49	179.27	0.00	30.1	400.12	0.400	13.34	109.66	31.61	671.41	11.64
2H & 3H	860	17.20	68.90	16.33	33.10	102.44	44.13	17.2	299.30	0.431	8.70	67.98	18.06	476.96	79.74

Level 3															
Column	Total Area (Ft ²)	Superimposed Kips/Floor	Slab/joist DL Kips/Floor	Beam DL Kips/Floor	Column DL Kips (est.)	Floor System DL Kips/Floor	Ext. Wall DL Kips/Floor	Roof DL Kips	Total DL Kips	LL Reduc.	Roof LL Kips	Total LL Kips	Roof SL Kips	Pu Kips	Mu Ft-K
1A & 4A	399	7.98	29.75	15.52	74.54	53.25	82.82	7.98	325.09	1.000	7.98	103.74	8.38	560.28	100.15
1B & 4B	714	14.28	53.24	27.77	49.69	95.29	70.40	14.28	420.24	0.412	7.58	78.19	14.99	636.89	106.69
1C & 4C	630	12.60	46.98	24.50	49.69	84.08	62.12	12.6	376.65	0.423	29.39	93.27	13.23	607.83	52.70
1D & 4D	630	12.60	46.98	24.50	49.69	84.08	62.12	12.6	376.65	0.423	29.39	93.27	13.23	607.83	52.19
1E & 4E	630	12.60	46.98	24.50	49.69	84.08	62.12	12.6	376.65	0.423	29.39	93.27	13.23	607.83	52.19
1F & 4F	630	12.60	46.98	24.50	49.69	84.08	62.12	12.6	376.65	0.423	29.39	93.27	13.23	607.83	52.70
1G & 4G	735	14.70	54.81	28.58	49.69	98.09	72.47	14.7	431.14	0.410	7.74	80.02	15.44	653.11	106.69
1H & 4H	420	8.40	31.32	16.33	74.54	56.05	84.89	8.4	335.99	0.461	5.17	51.67	8.82	490.27	101.92
2A & 3A	817	16.34	65.46	15.52	49.69	97.32	66.26	16.34	424.23	0.401	8.37	87.10	17.16	657.01	63.61
2B & 3B	1462	29.24	117.14	27.77	24.85	174.14	0.00	29.24	576.52	0.400	13.05	153.40	30.70	952.61	10.66
2C & 3C	1290	25.80	103.36	24.50	24.85	153.66	0.00	25.8	511.61	0.400	50.31	174.15	27.09	906.12	4.20
2D & 3D	1290	25.80	103.36	24.50	24.85	153.66	0.00	25.8	511.61	0.400	50.31	174.15	27.09	906.12	4.13
2E & 3E	1290	25.80	103.36	24.50	24.85	153.66	0.00	25.8	511.61	0.400	50.31	174.15	27.09	906.12	4.13
2F & 3F	1290	25.80	103.36	24.50	24.85	153.66	0.00	25.8	511.61	0.400	50.31	174.15	27.09	906.12	4.20
2G & 3G	1505	30.10	120.58	28.58	24.85	179.27	0.00	30.1	592.74	0.400	13.34	157.82	31.61	979.61	10.66
2H & 3H	860	17.20	68.90	16.33	49.69	102.44	66.26	17.2	440.46	0.400	8.70	91.26	18.06	683.60	70.19
Level 2															
Column	Total Area (Ft ²)	Superimposed Kips/Floor	Slab/joist DL Kips/Floor	Beam DL Kips/Floor	Column DL Kips (est.)	Floor System DL Kips/Floor	Ext. Wall DL Kips	Roof DL Kips	Total DL Kips	LL Reduc.	Roof LL Kips	Total LL Kips	Roof SL Kips	Pu Kips	Mu Ft-K
1A & 4A	399	7.98	29.75	15.52	99.43	53.25	110.48	7.98	430.90	1.000	7.98	135.66	8.38	738.32	135.44
1B & 4B	714	14.28	53.24	27.77	66.29	95.29	93.91	14.28	555.64	0.400	7.58	98.97	14.99	832.62	144.32
1C & 4C	630	12.60	46.98	24.50	66.29	84.08	82.86	12.6	498.07	0.400	29.39	110.03	13.23	780.35	72.68
1D & 4D	630	12.60	46.98	24.50	66.29	84.08	82.86	12.6	498.07	0.400	29.39	110.03	13.23	780.35	71.53
1E & 4E	630	12.60	46.98	24.50	66.29	84.08	82.86	12.6	498.07	0.400	29.39	110.03	13.23	780.35	71.53
1F & 4F	630	12.60	46.98	24.50	66.29	84.08	82.86	12.6	498.07	0.400	29.39	110.03	13.23	780.35	72.68
1G & 4G	735	14.70	54.81	28.58	66.29	98.09	96.67	14.7	570.04	0.400	7.74	101.82	15.44	854.67	144.32
1H & 4H	420	8.40	31.32	16.33	99.43	56.05	113.24	8.4	445.29	0.433	5.17	63.37	8.82	640.14	137.84
2A & 3A	817	16.34	65.46	15.52	66.29	97.32	88.38	16.34	560.27	0.400	8.37	112.95	17.16	861.62	86.09
2B & 3B	1462	29.24	117.14	27.77	33.14	174.14	0.00	29.24	758.96	0.400	13.05	200.18	30.70	1246.39	12.70
2C & 3C	1290	25.80	103.36	24.50	33.14	153.66	0.00	25.8	673.57	0.400	50.31	215.43	27.09	1166.51	5.26
2D & 3D	1290	25.80	103.36	24.50	33.14	153.66	0.00	25.8	673.57	0.400	50.31	215.43	27.09	1166.51	5.19
2E & 3E	1290	25.80	103.36	24.50	33.14	153.66	0.00	25.8	673.57	0.400	50.31	215.43	27.09	1166.51	5.19
2F & 3F	1290	25.80	103.36	24.50	33.14	153.66	0.00	25.8	673.57	0.400	50.31	215.43	27.09	1166.51	5.26
2G & 3G	1505	30.10	120.58	28.58	33.14	179.27	0.00	30.1	780.30	0.400	13.34	205.98	31.61	1281.74	12.70
2H & 3H	860	17.20	68.90	16.33	66.29	102.44	88.38	17.2	581.62	0.400	8.70	118.78	18.06	897.02	95.09
Level 1															
Column	Total Area (Ft ²)	Superimposed Kips/Floor	Slab/joist DL Kips/Floor	Beam DL Kips/Floor	Column DL Kips (est.)	Floor System DL Kips/Floor	Ext. Wall DL Kips/Floor	Roof DL Kips	Total DL Kips	LL Reduc.	Roof LL Kips	Total LL Kips	Roof SL Kips	Pu Kips	Mu Ft-K
1A & 4A	399	7.98	29.75	15.52	124.33	53.25	138.14	7.98	536.70	1.000	7.98	167.58	8.38	916.36	78.08
1B & 4B	714	14.28	53.24	27.77	82.88	95.29	117.42	14.28	691.04	0.400	7.58	121.82	14.99	1031.66	83.08
1C & 4C	630	12.60	46.98	24.50	82.88	84.08	103.61	12.6	619.49	0.400	29.39	130.19	13.23	958.31	42.16
1D & 4D	630	12.60	46.98	24.50	82.88	84.08	103.61	12.6	619.49	0.400	29.39	130.19	13.23	958.31	41.38
1E & 4E	630	12.60	46.98	24.50	82.88	84.08	103.61	12.6	619.49	0.400	29.39	130.19	13.23	958.31	41.38
1F & 4F	630	12.60	46.98	24.50	82.88	84.08	103.61	12.6	619.49	0.400	29.39	130.19	13.23	958.31	42.16
1G & 4G	735	14.70	54.81	28.58	82.88	98.09	120.87	14.7	708.93	0.400	7.74	125.34	15.44	1058.98	83.08
1H & 4H	420	8.40	31.32	16.33	124.33	56.05	141.59	8.4	554.59	0.414	5.17	74.67	8.82	789.39	79.47
2A & 3A	817	16.34	65.46	15.52	82.88	97.32	110.51	16.34	696.31	0.400	8.37	139.09	17.16	1066.70	47.72
2B & 3B	1462	29.24	117.14	27.77	41.44	174.14	0.00	29.24	941.40	0.400	13.05	246.97	30.70	1540.17	6.95
2C & 3C	1290	25.80	103.36	24.50	41.44	153.66	0.00	25.8	835.52	0.400	50.31	256.71	27.09	1426.91	2.95
2D & 3D	1290	25.80	103.36	24.50	41.44	153.66	0.00	25.8	835.52	0.400	50.31	256.71	27.09	1426.91	2.91
2E & 3E	1290	25.80	103.36	24.50	41.44	153.66	0.00	25.8	835.52	0.400	50.31	256.71	27.09	1426.91	2.91
2F & 3F	1290	25.80	103.36	24.50	41.44	153.66	0.00	25.8	835.52	0.400	50.31	256.71	27.09	1426.91	2.95
2G & 3G	1505	30.10	120.58	28.58	41.44	179.27	0.00	30.1	967.87	0.400	13.34	254.14	31.61	1583.87	6.95
2H & 3H	860	17.20	68.90	16.33	82.88	102.44	110.51	17.2	722.78	0.400	8.70	146.30	18.06	1110.45	52.86

Column design hand checks

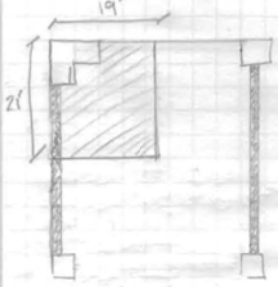
Column Axial Load for 1A and 4A	Final Report	Page 1 of 2						
	<p>Tributary Area = $19(21) = 399 \text{ ft}^2$ Length of Ext. wall carried = 40 ft Length of beam carried = 19 ft</p> <p>Slab Area carried = Total Area - Beam Area $= 399 - \left(\frac{32 \text{ in}}{12}\right)(19') = 348.33 \text{ ft}^2$</p> <p><u>Load Summary</u></p> <p>Roof DL = 20 psf Roof SL = 21 psf Floor LL = 80 psf Floor S.D.L = 20 psf Slab/Joist S.W. = 85.42 psf Beam self-weight = 816.67 lb/ft Exterior wall load = 50 psf</p> <p><u>Dead Loads</u></p> <p>P_0 of Slab/Joist = $348.33 \text{ ft}^2(85.42 \text{ psf}) = 29.75 \text{ k}$ (per story) P_0 of S.D.L = $399 \text{ ft}^2(20 \text{ psf}) = 7.98 \text{ k}$ (per story) P_0 of Beam load = $19 \text{ ft}(816.67 \text{ lb/ft}) = 15.52 \text{ k}$ (per story) P_0 for total floor system = $29.75 + 7.98 + 15.52 = 53.25 \text{ k}$ (per story)</p> <p><u>Design Column 1A and 4A for the 1st Level</u></p> <p>P_0 for floor system = 53.25 k (per story)</p> <p>P_0 for above columns (estimated) = $\frac{1728 \text{ m}^2(15 \text{ psf})}{(144 \text{ in}^2/\text{ft}^2)(1000)} (69.07 \text{ ft}) = 124.33 \text{ k}$ column height above</p> <p>P_0 for ext. wall load = $(50 \text{ psf})(40 \text{ ft})(69.07 \text{ ft}) = 138.14 \text{ k}$</p> <p>$P_0$ for roof = $(20 \text{ psf})(399 \text{ ft}^2) = 7.98 \text{ k}$</p> <p>* 1st floor columns support 5 stories above</p> <p>TOTAL DL = $7.98 + 138.14 + 124.33 + (5)(53.25) = 536.7 \text{ k}$</p> <p><u>Live Loads</u></p> <p>$L_{load} = \left(25 + \frac{15}{\sqrt{K_1 A_r}}\right)$ * No LL reduction is permitted for influence areas less than 400 ft^2</p> <p>P_L for roof = $(20 \text{ psf})(399 \text{ ft}^2) = 7.98 \text{ k}$</p> <p>$P_L$ for Floors = $(80 \text{ psf})(399 \text{ ft}^2)(5) = 159.6 \text{ k}$</p> <p>TOTAL LL = $159.6 \text{ k} + 7.98 \text{ k} = 167.58 \text{ k}$</p>	<table border="1" style="width: 100%; border-collapse: collapse;"> <thead> <tr> <th style="width: 30%;">Column Axial Load for 1A and 4A</th> <th style="width: 30%;">Final Report</th> <th style="width: 40%;">Page 2 of 2</th> </tr> </thead> <tbody> <tr> <td style="vertical-align: top;"> <p>Roof Snow Load</p> <p>$P_0 = 21 \text{ psf}(399 \text{ ft}^2) = 8.38 \text{ k}$</p> <p>Total Axial Load = $1.2 P_0 + 1.6 P_L + 0.5 P_s = 1.2(536.7) + 1.6(167.58) + 0.5(8.38)$</p> <p>= 916.36 k</p> </td> <td></td> <td></td> </tr> </tbody> </table>	Column Axial Load for 1A and 4A	Final Report	Page 2 of 2	<p>Roof Snow Load</p> <p>$P_0 = 21 \text{ psf}(399 \text{ ft}^2) = 8.38 \text{ k}$</p> <p>Total Axial Load = $1.2 P_0 + 1.6 P_L + 0.5 P_s = 1.2(536.7) + 1.6(167.58) + 0.5(8.38)$</p> <p>= 916.36 k</p>		
Column Axial Load for 1A and 4A	Final Report	Page 2 of 2						
<p>Roof Snow Load</p> <p>$P_0 = 21 \text{ psf}(399 \text{ ft}^2) = 8.38 \text{ k}$</p> <p>Total Axial Load = $1.2 P_0 + 1.6 P_L + 0.5 P_s = 1.2(536.7) + 1.6(167.58) + 0.5(8.38)$</p> <p>= 916.36 k</p>								

Column Axial Load Typical Column	Final Report	Page 1 of 1
	<p>Tributary Area = $43' \times 30' = 1290 \text{ ft}^2$ Length of Ext wall = 0 ft Length of Beam carried = 30 ft</p> <p>Slab Area carried = Total Area - Beam Area $= 1290 - \left(\frac{32}{12}\right)(30) = 1210 \text{ ft}^2$</p> <p><u>Load summary</u></p> <p>Roof DL = 20 psf Floor S.D.L. = 20 psf Roof SL = 21 psf Slab joist S.W. = 85.42 psf Floor LL = 80 psf Beam self weight = 816.67 lb/ft Mech LL = 150 psf Exterior wall load = 50 psf</p>	
<p><u>Dead Loads</u></p> <p>P_{DL} of slab/joist = $1210 \text{ ft}^2 (85.42 \text{ psf}) = 103.36 \text{ k}$ (per story) P_{DL} of S.D.L. = $1290 \text{ ft}^2 (20 \text{ psf}) = 25.8 \text{ k}$ (per story) P_{DL} of Beam load = $30 \text{ ft} (816.67 \text{ lb/ft}) = 24.5 \text{ k}$ (per story) P_{DL} of total floor system = $103.36 + 25.8 + 24.5 = 153.66 \text{ k}$ (per story)</p> <p><u>Design Column 2C, 3C, 2D, 3D, 2E, 3E, 2F, 3F for the 1st level</u></p> <p>P_{DL} for above columns (estimated) = $\frac{(24 \text{ in})(24 \text{ in})(150 \text{ psf})}{(144 \text{ in}^2/\text{ft}^2)(1000)} (69.07 \text{ ft}) = 41.44 \text{ k}$ P_{DL} for Ext. wall Load = 0 k P_{DL} for Roof = $(20 \text{ psf})(1290 \text{ ft}^2) = 25.8 \text{ k}$ * first floor columns support 5 stories</p> <p>TOTAL DL = $25.8 \text{ k} + 0 \text{ k} + 41.44 \text{ k} + 5(153.66 \text{ k}) = 835.54 \text{ k}$</p>		
	<p><u>Live Loads</u></p> <p>Roof LLred = $\left(.25 + \frac{15}{\sqrt{144} A_T}\right) = \left(.25 + \frac{15}{\sqrt{144}(1290)}\right) = 0.459$ P_L for roof = $0.459(20)(645 \text{ ft}^2) + (0.459)(150)(645 \text{ ft}^2) = 50.33 \text{ k}$</p> <p>Floor LLred = $\left(.25 + \frac{15}{\sqrt{144} A_T}\right) = \left(.25 + \frac{15}{\sqrt{144}(1290)}\right) = .343 < 0.4 \Rightarrow \text{USE } 0.4$ P_L for floor = $(80 \text{ psf})(1290 \text{ ft}^2)(.4) = 206.4 \text{ k}$</p> <p>TOTAL LL = $50.33 + 206.4 = 256.73 \text{ k}$</p> <p>Roof SL = $P_{DL} = 21 \text{ psf}(1290) = 27.09 \text{ k}$</p>	
	<p>TOTAL AXIAL LOAD = $1.2(835.54) + 1.6(256.73) + 0.5(27.09)$ $= 1426.96 \text{ k}$</p>	

column design checks

Final Report

Page 1 of 5

Level 1: Columns 2B, 3B, 2E, 3E (largest axial load)

$P_u = 1540.17^k$ - square column $f'_c = 4 \text{ ksi}$
 $M_u = 7 \text{ ft-k}$ - bars in 4 faces $f_y = 60 \text{ ksi}$

- assume $\rho_g = 0.015$

$$A_{g, \text{trial}} = \frac{P_u}{0.4[f'_c + f_y \rho_g]} = \frac{1540.17^k}{1.96} = 785.80 \text{ in}^2$$

$$A_{g, \text{trial}} \Rightarrow \sqrt{785.80} = 28.03 \Rightarrow \text{try } 30" \times 30"$$

* assume slenderness is neglected

$$\gamma = \frac{30 - 5}{30} = .833$$

Determine ρ_g : $\frac{P_u}{A_g} = \frac{1540.17}{900} = 1.71$ $\frac{M_u}{A_g h} = \frac{7(12)}{900(18)} \approx 0$

for $\gamma = 0.75 \Rightarrow \rho_g \leq 0.01$
 for $\gamma = 0.90 \Rightarrow \rho_g \leq 0.01$ } $\rho_g = 0.01$

$$A_{st} = A_g \rho_g = 900(0.01) = 9 \text{ in}^2 \Rightarrow \text{try } 12 \# 8 \text{ bars} \Rightarrow A_s = 9.48 \text{ in}^2$$

$$\text{max load capacity} = \phi P_n, \text{max} = 0.8(0.65) [0.85(4)(900 - 9.48) + 60(9.48)] = 1870.2$$

$$1672.28 < 1870.2 \quad \checkmark \text{ ok}$$

Use 30" x 30" column with 12# 8 bars

Select ties: spacing = $\min \left\{ \begin{array}{l} 16d_b = 16(1.128) = 18 \\ 48d_s = 48(3/8) = 18 \end{array} \right. = 18 = 18" \text{ spacing}$

Use #3 ties at 18" o.c.

design lap splices: $l_d = \frac{f_y \psi_t \psi_e d_b}{20 \sqrt{f'_c}}$

$$l_d = \frac{60000(1)(1)(1.128)}{20(1) \sqrt{4000}} = 53.5 \text{ in}$$

splice length = $1.3 l_d = 69.56 \text{ in}$

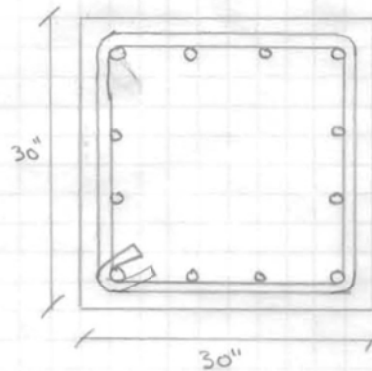

column Design checks	Final Report	Page 2 of 5
----------------------	--------------	-------------

Level 1: (1B, 4B, 1F, 4F) (Extension columns)

$P_u = 1058.98$ - rectangular column
 $M_u = 83.08$ - bars in 4 faces

$f'_c = 4 \text{ ksi}$
 $f_y = 60 \text{ ksi}$

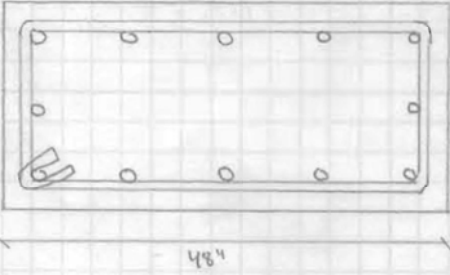

Rein = 12 #9 bars

$A_{se} = 12 \text{ in}^2$

clear cover = 2.87 in

spacing between bars = $\frac{48 - 2(2.87)}{4} = 10.57$

Max load capacity

$$\phi P_{n, \max} = .8(65) [85(4)(48 - 2(2.87)) + 60(12)] = 2389.92 \text{ k}$$

Balanced condition

$$\epsilon_y = \frac{60}{29000} = .0021 \quad c = \frac{.003}{.003 + .0021} (48 - 2.87) = 26.55$$

$$\epsilon_{s1} = \left(\frac{c - d_1}{c} \right) (.003) = \frac{26.55 - 2.87}{26.55} (.003) = .00267 \quad f_{s1} = 60 \text{ ksi}$$

$$\epsilon_{s2} = \left(\frac{26.55 - 13.44}{26.55} \right) (.003) = .00148 \quad f_{s2} = 42.96 \text{ ksi}$$

$$\epsilon_{s3} = \left(\frac{26.55 - 24.01}{26.55} \right) (.003) = 2.87 \text{ c-4} \quad f_{s3} = 8.32 \text{ ksi}$$

$$\epsilon_{s4} = \left(\frac{26.55 - 34.58}{26.55} \right) (.003) = -9.073 \text{ c-4} \quad f_{s4} = -26.31 \text{ ksi}$$

$$\epsilon_{s5} = \left(\frac{26.55 - 43.15}{26.55} \right) (.003) = -.00210 \quad f_{s5} = -60 \text{ ksi}$$

Find: $a = \beta_1 c = .85(26.55) = 22.56 < 24 \text{ in} \quad \checkmark \text{ ok}$

$$C_c = 0.85 f'_c (ab) = 0.85(4)(22.56)(24) = 1840.9 \text{ k}$$

$$F_1 = f_y A_{s1} = 60(3) = 180 \text{ k}$$

$$F_2 = f_{s2} A_{s2} = 42.96(2) = 85.92 \text{ k}$$

$$F_3 = f_{s3} A_{s3} = 8.32(1) = 8.32 \text{ k}$$

$$F_4 = f_{s4} A_{s4} = -26.31(2) = -52.62 \text{ k}$$

$$F_5 = f_{s5} A_{s5} = (-60)(3) = -180 \text{ k}$$

3-0235 - 50 SHEETS - 5 SQUARES
 3-0236 - 100 SHEETS - 5 SQUARES
 3-0237 - 200 SHEETS - 5 SQUARES
 3-0137 - 200 SHEETS - FILLER

COMET

	Column Design checks	Fiber Report	Page 3 of 5
3-0235 — 50 SHEETS — 5 SQUARES 3-0236 — 100 SHEETS — 5 SQUARES 3-0237 — 200 SHEETS — 5 SQUARES 3-0137 — 200 SHEETS — FILLER	$M_n = C_c \left(\frac{h}{2} - \frac{a}{2} \right) + F_{s1} \left(\frac{h}{2} - d_1 \right) + F_{s2} \left(\frac{h}{2} - d_2 \right) + F_{s3} \left(\frac{h}{2} - d_3 \right) + F_{s4} \left(\frac{h}{2} - d_4 \right) + F_{s5} \left(\frac{h}{2} - d_5 \right)$		
	$M_n = 1840.9 \left(\frac{48}{2} - \frac{22.56}{2} \right) + 180 \left(\frac{48}{2} - \frac{2.87}{2} \right) + 85.92 \left(\frac{48}{2} - \frac{13.44}{2} \right) + 16.64 \left(\frac{48 - 24.01}{2} \right) - 52.62 \left(\frac{48 - 34.58}{2} \right) - 180 \left(\frac{48 - 45.15}{2} \right)$		
	$= 23416.75 + 4061.7 + 1484.7 + 199.6 - 353.08 - 256.5 = 2379.39 \text{ ft}\cdot\text{k}$		
	$P_n = C_c + \sum F_{si} = 1840.9 + 180 + 85.92 + 16.64 - 52.62 - 180 = 1890.84$		
COMET	$\phi P_n = .65(1890.84) = 1229.05 \text{ k} > 1058.98 \text{ k} \quad \checkmark \text{ ok}$		
	$\phi M_n = .65(2379.39) = 1546.6 \text{ k} > 83.08 \text{ k} \quad \checkmark \text{ ok}$		
	<p>Exterior columns at Level 2 (10, 4B, 10, 4E)</p> $P_u = 854.67 \text{ k} < 1229.05 \text{ k} \quad \checkmark \text{ ok}$ $M_u = 144.32 \text{ ft}\cdot\text{k} < 1546.6 \text{ ft}\cdot\text{k} \quad \checkmark \text{ ok}$		

Column Design Hand Checks	Final Report	Page 4 of 5
---------------------------	--------------	-------------

Level 2: corner columns (1A, 4A, 1H, 4H)

$P_u = 916.36$ - L shaped irregular
 $M_u = 79.47$ - bars in all faces

$f'_c = 4 \text{ ksi}$
 $f_y = 60 \text{ ksi}$

- assume $\rho_g = 0.015$ $A_{g, \text{trial}} \geq \frac{P_u}{0.4(f'_c + f_y \rho_g)} = \frac{916.36}{0.4(4 + 60(0.015))} = \frac{916.36}{1.96}$

- use 48" x 48" L shaped column

* assume slenderness is neglected

$\delta = \frac{22-5}{22} = .773$ determine ρ_g : $\frac{P_u}{A_g} = \frac{801.69}{400} = 2$ $\frac{M_u}{A_g h} = \frac{79.47(12)}{400(18)} = .132$

for $\delta = 0.75 \Rightarrow \rho_g = 0.015$

$A_{g, \text{req}} = \rho_g A_g = 0.015(400) = 6 \text{ in}^2 \Rightarrow$ use 12# 7 bars $\Rightarrow A_g = 7.2 \text{ in}^2$

max load capacity: $\phi P_n, \text{max} = 0.8(0.65) [0.85(4)(400 - 7.2) + 60(7.2)] = 919.11$

$919.11 > 801.69$ ✓ ok

use 20" x 20" column with 12# 7 bars

Select ties:

16d ₆	= 16(0.875) = 14
48d ₈	= 48(0.375) = 18 = 14" spacing
min	18" = 18" = 18"

use #3 ties at 14" o.c.

Design lap splices: $l_d = \frac{f_y \phi_c \phi_e d_b}{20.7 \sqrt{f'_c}} = \frac{60000(1)(1)(0.875)}{20(1)(\sqrt{4000})} = 41.5 \text{ in}$

splice length = 1.3l_d = 53.95 in

20"
20"

24"
48"
48"
24"

* Based on this calculation, it can be assumed that a 48" x 48" L-shaped column will be more than sufficient for gravity loading

Level 1: Columns 2C, 3C, 2D, 3D, 2E, 3E, 2F, 3F (typical interior column)

$P_u = 1426.96 \text{ k}$ - square column $f'_c = 4 \text{ ksi}$
 $M_u = 3 \text{ ft-k}$ - bars in 4 faces $f_y = 60 \text{ ksi}$

- assume $P_g = 0.015$

$$A_{g, \text{trial}} = \frac{P_u}{1.46} = \frac{1426.96}{1.46} = 728.04 \text{ in}^2$$

$$A_{g, \text{trial}} \Rightarrow \sqrt{728.04} = 26.98 \text{ in} \Rightarrow \text{try } 26" \times 26"$$

→ assume slenderness is neglected

$$\gamma = \frac{26-5}{26} = .808$$

Determine P_g : $\frac{P_g}{A_g} = \frac{1426.96}{676} = 2.11$ $\frac{M_u}{A_g} = \frac{3(12)}{676(18)} = .003 \ll 0$

for $\gamma = 0.75 \Rightarrow P_g = 0.011$
 for $\gamma = 0.90 \Rightarrow P_g = 0.01$ } $P_g = 0.01$

$$A_{st} = A_g P_g = 676(.01) = 6.76 \text{ in}^2 \Rightarrow \text{try } 12 \# \text{ bars} \Rightarrow A_{st} = 7.2 \text{ in}^2$$

max load capacity: $\phi P_n = 0.8(0.65) [.85(4)(676 - 7.2) + 60(7.2)] = 1407.08 \text{ k}$

Try 8 #9 bars $\Rightarrow A_{st} = 8 \text{ in}^2 \Rightarrow \phi P_n = 1430.62 > 1426.96 \text{ k} \checkmark \text{ ok}$

Use 26" x 26" column with 8 #9 bars

Select ties: spacing = m.in

$\frac{16d_b}{48d_s} = \frac{16(1.125)}{48(1.375)} = 18"$	$\frac{16d_b}{18} = \frac{16(1.125)}{18} = 18"$	$\frac{16d_b}{18} = 18"$	= 18" spacing
---	---	--------------------------	---------------

use #3 ties at 18" o.c.

design lap splices: $l_d = \frac{f_y \psi_t \psi_s d_b}{20 \sqrt{f'_c}} = \frac{60000(1)(1)(1.125)}{20(1)\sqrt{4000}} = 53.5$

splice length = $1.3 l_d = 69.55$

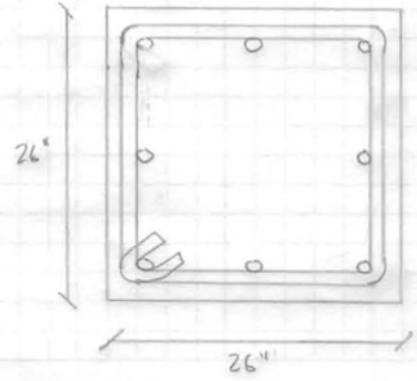

SP Column design checks

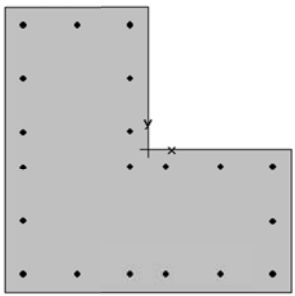

48 x 48 in
 1.16% reinf.

MATERIAL:
 =====
 f'c = 4 ksi
 Ec = 3605 ksi
 fc = 3.4 ksi
 Beta1 = 0.85
 fy = 60 ksi
 Es = 29000 ksi

SECTION:
 =====
 Ag = 1728 in²
 Ix = 304128 in⁴
 Iy = 304128 in⁴
 Xo = -4 in
 Yo = -4 in

REINFORCEMENT:
 =====
 20 #9 bars @ 1.157%
 As = 20 in²
 Confinement: Tied
 Clear Cover = N/A
 Min Clear Spacing = 4.87 in

SLENDERNESS:
 =====
 N/A

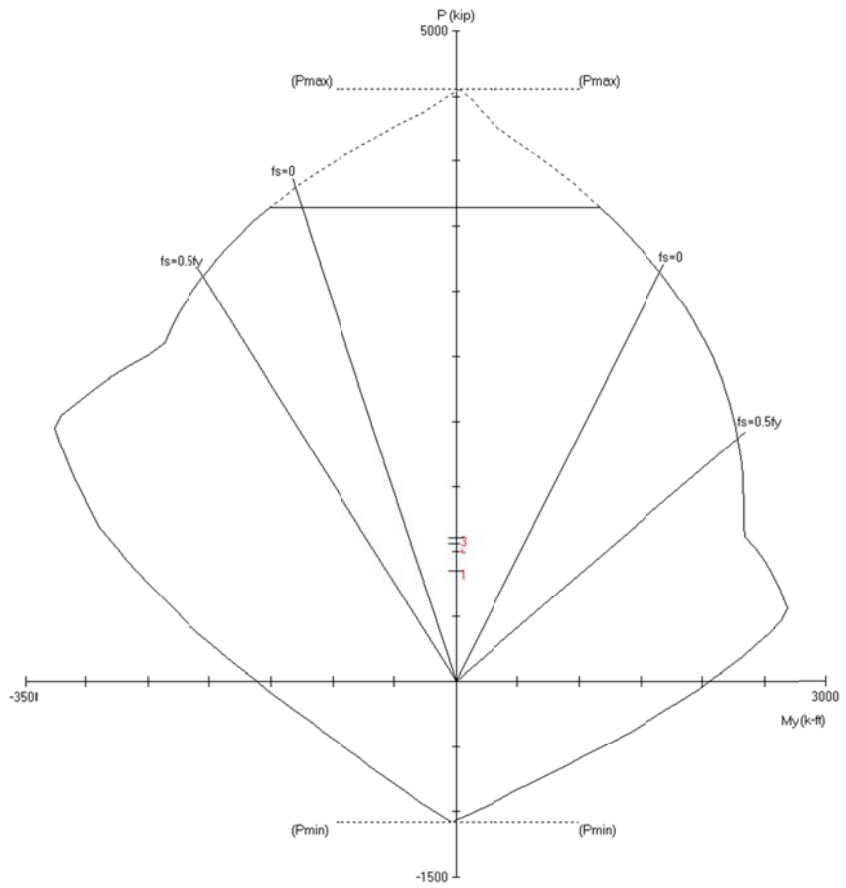

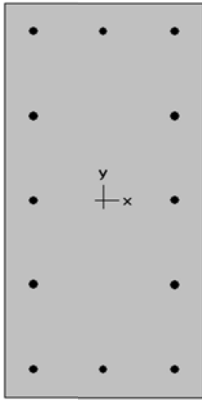

24 x 48 in
 1.04% reinf.

MATERIAL:
 =====
 = 4 ksi
 = 3605 ksi
 = 3.4 ksi
 = 0.85
 = 60 ksi
 = 29000 ksi

SECTION:
 =====
 = 1152 in²
 = 221184 in⁴
 = 55296 in⁴
 = 0 in
 = 0 in

REINFORCEMENT:
 =====
 #9 bars @ 1.042%
 = 12 in²
 confinement: Tied
 clear Cover = 2.87 in
 clear Spacing = 7.43 in

REMARKS:
 =====
 A

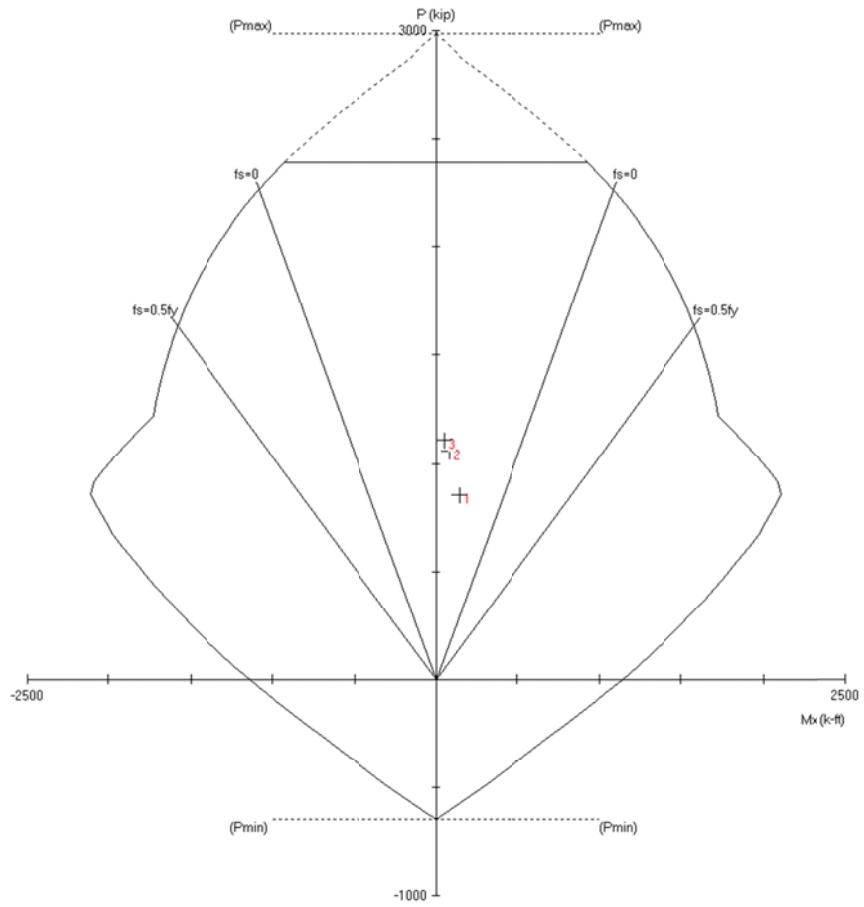

Appendix C: Wind Load Calculations

TABLE C.1 - Estimated Natural Frequency Check (N/S)

Effective Length (Ft.)	86.92	
26.9.2.1 Req't #1	81.75 < 300?	YES, OK
26.9.2.1 Req't #2	81.75 < 4*86.92?	YES, OK
Concrete Moment Frame	$n_a = .827 < 1$	Flexible Structure

TABLE C.2 - Flexible Gust Effect Factor Calculation

Variable	East/West	North/South
n_a	.827	.827
g_q	3.4	3.4
g_v	3.4	3.4
g_r	4.13	4.13
I_z	.1853	.1853
Q	.861	.832
R	.0362	.0313
G_f	.859	.845

TABLE C.3 - Wind Force Variables

Variable	Symbol	E/W Value	N/S Value
Directionality Factor	K_d	0.85	0.85
	K_h	1.21	1.21
	α	9.5	9.5
	Z_g	900	900
Topographic Factor	K_{zt}	1.0	1.0
Flexible Gust Effect Factor	G_f	.859	.845
Internal Pressure Coefficient	GC_{pi}	+/- 0.18	+/- 0.18
Windward Wall Coefficient	C_p	0.8	0.8
Leeward Wall Coefficient	C_p	-0.34	-0.5
Side Wall Coefficient	C_p	-0.7	-0.7
Roof Coefficient (0 to 40.88)	C_p	-0.9	-1.01
Roof Coefficient (40.88 to 81.75)	C_p	-0.9	-0.84
Roof Coefficient (81.75 to 163.5)	C_p	-0.5	-0.56
Roof Coefficient (163.5 to 228)	C_p	-0.3	- -
Roof Coefficient Pt. A	C_{pa}	-1.173	-1.173
Roof Coefficient Pt. B	C_{pb}	-1.1	-1.1
Roof Coefficient Pt. C	C_{pc}	-0.5	-0.5

Wind Analysis	Final Report	Page 1 of 6
---------------	--------------	-------------

USE ASCE 7-05 chapter 6.5 - Method 2 MWFES Analytical procedure

Wind Direction: North/South (constants)

Basic wind speed: 90 mph

Building classification: II (table 1-1)

Importance Factor: I = 1.0 (table 6-1)

Exposure Category: C

Directionality Factor: $K_d = 0.85$

$h = 81.92 \text{ ft} \Rightarrow$ Interpolate K_h

height	K_h	$\rightarrow \frac{90-80}{1.24-1.21} = \frac{81.92-80}{K_h-1.21} \Rightarrow K_h = 1.21$
80	1.21	
81.75		
90	1.24	

For k_2 values, see attached spreadsheet

$K_2 = 2.01 \left(\frac{z}{z_g} \right)^{2/\alpha}$ $\alpha = 9.5$ (table 6-2)
 $z_g = 900$ (table 6-2)

Topographic Factor: $K_{zt} = (1 + k_1 \cdot k_2 \cdot k_3)^2$

No ridges or Escarpments are present on site $\Rightarrow K_{zt} = 1.0$

Gust Effect Factor

Use ASCE 7-10 to estimate the natural frequency: (chapter 26.9)

$$L_{eff} = \frac{\sum_{i=1}^n h_i \cdot l_i}{\sum_{i=1}^n h_i} = \frac{128(17.17+30.2+43.2+56.2+69.2+81.75) + 27.2(94) + 22.67(103)}{494.72}$$

$L_{eff} = \frac{43000}{494.72} = 86.92 \text{ ft} \Rightarrow 86.92 < 4(81.75) \checkmark \text{ ok}$

Building height: $81.75 < 300 \checkmark \text{ ok}$

Therefore: Building natural frequency can be approximated

For concrete moment resisting frame buildings: $n_n = 43.5/h^{0.9}$

$$n_n = \frac{43.5}{81.75^{0.9}} = \frac{43.5}{52.63} = .827 \text{ Hz}$$

$n_n = .827 < 1 \Rightarrow$ Flexible structure

Wind Analysis	Final Report	Page 2 of 6
$G_s = 0.925 \left[\frac{1 + 1.7 I_z \sqrt{g_q^2 Q^2 + g_r^2 R^2}}{1 + 1.7 g_v I_z} \right] \quad g_q = g_v = 3.4$		
$g_r = \sqrt{2 \ln(3600)(n_s)} + \frac{0.577}{\sqrt{2 \ln(3600)(n_s)}}$		
$g_r = \sqrt{2 \ln(3600 \cdot 827)} + \frac{0.577}{\sqrt{2 \ln(3600 \cdot 827)}} = 4.130$		
<p>To calculate R:</p>		
$z_{mh} = 15 \text{ ft}, \alpha = 9.5, l(81) = 500, \bar{E} = 0.2, \bar{\alpha} = 1/6.5, \bar{b} = 0.65$		
$z = \max \left \frac{0.6z}{z_{mh}} \right = \max \left \frac{0.6(81.75)}{15} \right = 49.05 \text{ ft}$		
$L_z = l \left(\frac{z}{33} \right)^{\bar{E}} = 500 \left(\frac{49.05}{33} \right)^{0.2} = 541.25$		
$\bar{V}_z = \bar{b} \left(\frac{z}{33} \right)^{\bar{\alpha}} V \left(\frac{88}{60} \right) = 0.65 \left(\frac{49.05}{33} \right)^{1/6.5} (90) \left(\frac{88}{60} \right) = 91.19$		
$N_1 = \frac{n_1 L_z}{\bar{V}_z} = \frac{.827(541.25)}{91.19} = 4.91$		
$R_n = \frac{7.47 N_1}{(1 + 10.3 N_1)^{5/3}} = \frac{7.47(4.91)}{(1 + 10.3(4.91))^{5/3}} = .051$		
<p>For $R_h \Rightarrow \eta = \frac{4.6 n_1 h}{\bar{V}_z} = \frac{4.6(.827)(81.75)}{91.19} = 3.41$</p>		
$R_h = \frac{1}{\eta_h} - \frac{1}{2\eta_h^2} (1 - e^{-2\eta_h}) = \frac{1}{3.397} - \frac{1}{2(3.397)^2} (1 - e^{-2(3.397)}) = .2511$		
<p>For $R_B \Rightarrow \eta_B = \frac{4.6 n_1 E B}{\bar{V}_z}$ where $B = 228 \text{ ft}$ and $E = 1$</p>		
$\eta_B = \frac{4.6(.781)(1)(228)}{92.09} = 9.42 \quad R_B = \frac{1}{\eta_B} - \frac{1}{2(\eta_B)^2} (1 - e^{-2(9.42)}) = .1005$		
<p>For $R_L \Rightarrow \eta_L = \frac{15.4 n_1 L}{\bar{V}_z}$ where $L = 128 \text{ ft}$ $\eta_L = \frac{15.4(.781)(128)}{92.09} = 17.88$</p>		
$R_L = \frac{1}{\eta_L} - \frac{1}{2\eta_L^2} (1 - e^{-2\eta_L}) = \frac{1}{16.72} - \frac{1}{2(16.72)^2} (1 - e^{-2(16.72)}) = .054$		
$R = \sqrt[5]{\frac{1}{8} R_n R_h R_B (0.53 + 0.47 R_L)} = \sqrt[5]{\left(\frac{1}{8}\right) (.051) (.251) (.1005) (.51 + 0.47(.054))}$		
<div style="border: 1px solid black; padding: 5px; display: inline-block;"> $R = .0313$ </div>		

Wind Analysis

Final Report

Page 3 of 6

$$I_z = c \left(\frac{33}{z} \right)^{1/6} \quad \text{where } c = 0.2 \text{ (table 6-2)} \quad I_z = 0.2 \left(\frac{33}{52.25} \right)^{1/6} = .1853$$

$$Q = \sqrt{\frac{1}{1 + 0.63 \left(\frac{R+h}{L_s} \right)^{0.63}}} = \sqrt{\frac{1}{1 + 0.63 \left(\frac{228 + 82.75}{541.25} \right)^{0.63}}} = 0.832$$

$$G_s = 0.925 \left(\frac{1 + 1.7 I_z \sqrt{3 Q^2 R^2 + g_s^2 R^2}}{1 + 1.7 g_s I_z} \right) = 0.925 \left(\frac{1 + 1.7 (.1853) \sqrt{3 (.832)^2 + 4.13^2 (.0319)^2}}{1 + 1.7 (3.4) (.1853)} \right)$$

$$G_s = 0.8449$$

Enclosure Classification: Enclosed

Internal pressure coeff: $C_{pi} = \pm 0.18$

External pressure coeff: C_p

Walls and roof:

windward wall: $C_p = 0.8$ (use with q_z)

leeward wall: For $\frac{L}{B} = \frac{128}{228} < 1 \Rightarrow C_p = -0.5$ (use with q_h)

Sidewall: $C_p = -0.7$ (use with q_h)

Roof: $\frac{h}{L} = \frac{81.75}{128} = .64 > 0.5$

Interpolate: for 0 to $\frac{h}{2} \Rightarrow \frac{1-0.5}{0+0.9} = \frac{1-.64}{-1.3-C_p} \Rightarrow C_p = -1.01$

for $\frac{h}{2}$ to $h \Rightarrow \frac{1-0.5}{-0.7+0.9} = \frac{1-.64}{-0.7-C_p} \Rightarrow C_p = -0.84$

for h to $2h \Rightarrow \frac{1-0.5}{-0.7+0.5} = \frac{1-.64}{-0.7-C_p} \Rightarrow C_p = -0.56$

Domed Turret Roof

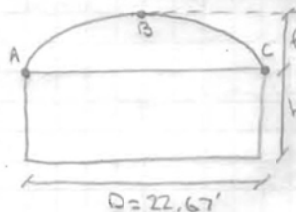

$$\frac{h_b}{D} = \frac{16.25}{22.67} = .717 \quad \frac{f}{D} = \frac{5}{22.67} = .221$$

$$\text{for } \frac{f}{D} = .221 \Rightarrow A \left(\frac{h_b}{D} = 0.25 \right) = -0.55$$

$$A \left(\frac{h_b}{D} \geq 1.0 \right) = -1.55$$

$$\text{interpolate: } \frac{.717-.25}{1-.25} = \frac{C_p+0.55}{-1.55+0.55} \Rightarrow C_{pA} = -1.173$$

Wind Analysis

Final Report

Page 4 of 6

$B(\frac{hb}{D} \geq 0.5) \Rightarrow -1.1$

$C_{PB} = -1.1$

$C(\frac{hb}{D} \geq 0.5) \Rightarrow$

$C_{PC} = -0.5$

Velocity Pressures: see attached spreadsheet

$q_z = 0.00256 K_z K_{zt} K_d V^2 I = 17.6255 K_z$

where: $K_{zt} = 1.0, K_d = 0.85, V = 90, I = 1.0$

External Pressure = $q_z G_s C_p \Rightarrow$ see spreadsheet for values

Design wind loads:

For exterior buildings: $P = q_z G_s C_p - q_i (G C_{pi})$

* see spreadsheet for design loads and pressures

Story Force Diagram (N/s) (see spreadsheet for notes)

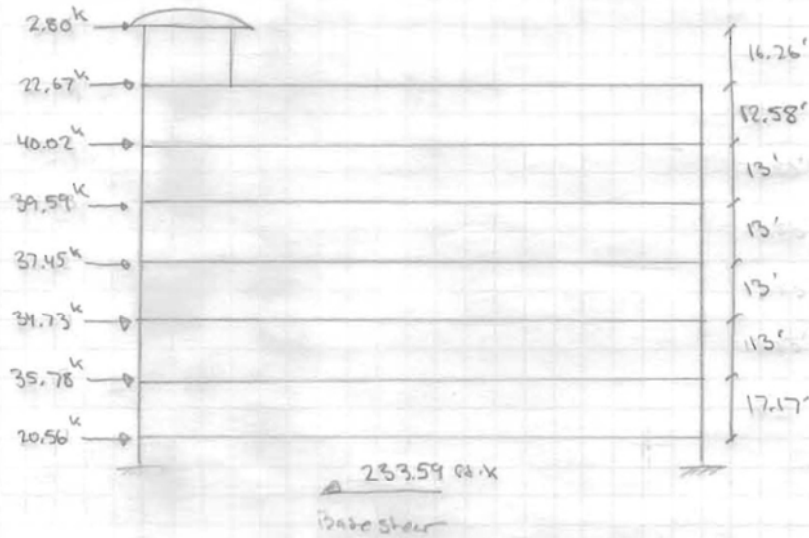

Wind analysis	Final Report	Page 5 of 6
<p><u>Direction:</u> East/West</p> <p><u>Gust Effect Factor:</u></p> $L_{eff} = \frac{\sum_{i=1}^n h_i L_i}{\sum_{i=1}^n h_i} = \frac{228(17.2+30.2+43.2+56.2+69.2+81.75) + 27.2(94.3) + 22.67(103)}{494.75}$ $L_{eff} = \frac{7278.8}{494.75} = 147.10 \text{ ft} \Rightarrow 87.0824(147.10)$ <p>∴ Natural frequency can be approximated $\Rightarrow n_a = .827$</p> <p><u>Calculate R:</u></p> <p>For $R_B \Rightarrow \eta_B = \frac{4.6 \eta_1 E B}{V_2}$ where $B = 128 \text{ ft}$ and $E = 1$</p> $\eta_B = \frac{4.6(.78)(1)(128)}{92.09} = 4.99 \quad R_B = \frac{1}{4.99} - \frac{1}{2(4.99)^2} (1 - e^{-2(4.99)}) = .1803$ <p>For $R_L \Rightarrow \eta_L = \frac{15.4(\eta_1) L}{V_2} = \frac{15.4(.78)(228)}{92.09} = 29.78$</p> $R_L = \frac{1}{29.78} - \frac{1}{2(29.78)^2} (1 - e^{-2(29.78)}) = .0330$ <p><u>Resonance Response Factor:</u> $R = \sqrt{\frac{1}{8} R_n R_h R_B (.53 + 0.47 R_L)}$ where $B = 1$</p> $R = \sqrt{\left(\frac{1}{8}\right)(.053)(.2511)(.1803)(.53 + .47(.0330))}$ $R = .0362$ $Q = \sqrt{\frac{1}{1 + 0.63 \left(\frac{B+h}{L}\right)^{0.63}}} = \sqrt{\frac{1}{1 + 0.63 \left(\frac{128+87.08}{548.13}\right)^{0.63}}} = 0.861$ <p><u>Flexible Gust Effect Factor:</u></p> $G_s = 0.925 \left(\frac{1 + 1.7(.1853) \sqrt{3.4^2(.861)^2 + 4.13^2(.0362)^2}}{1 + 1.7(3.4)(.1853)} \right) = .8590$		

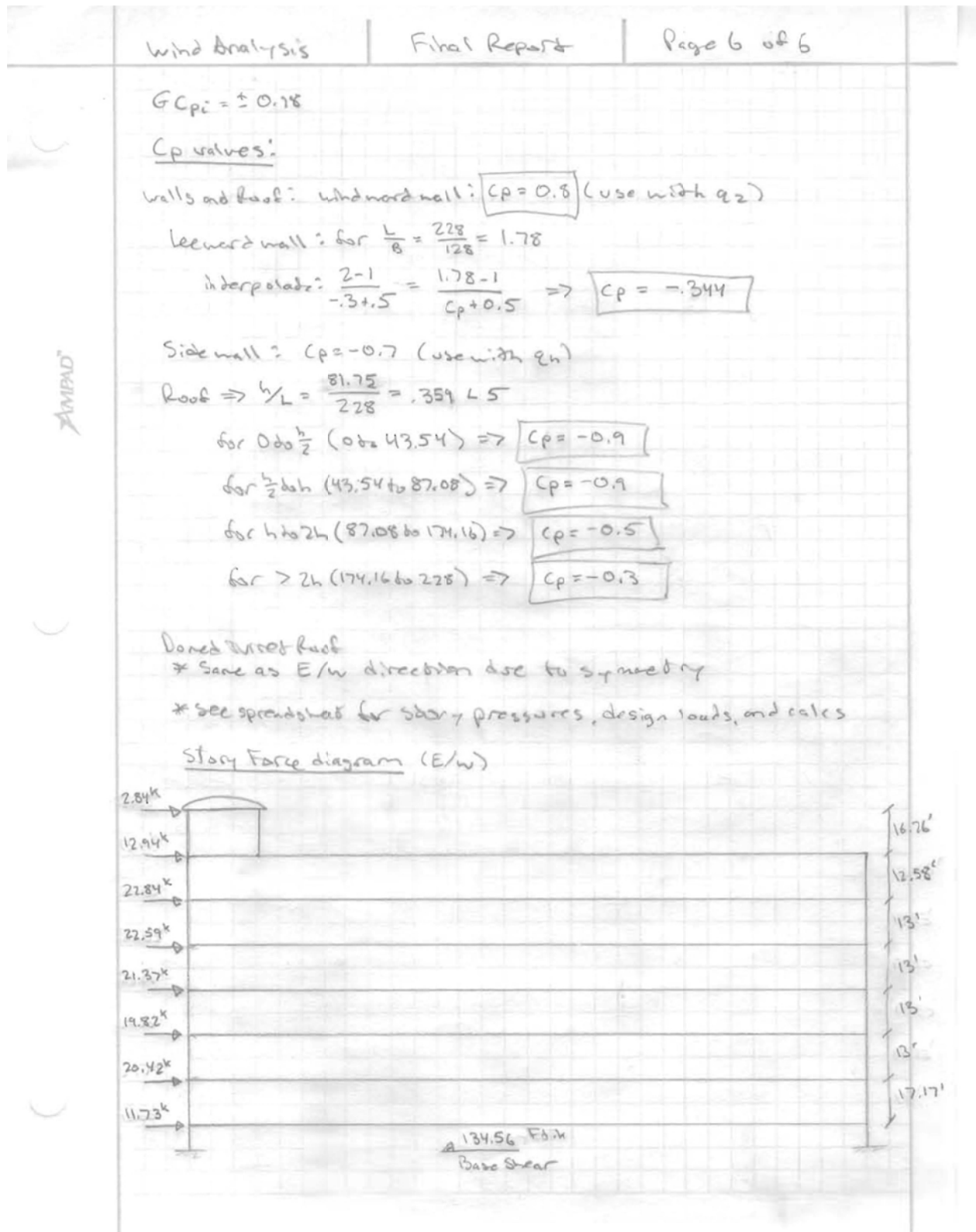

Appendix D: Seismic Calculations

TABLE D.1 - Level 1 Concrete Framing Weight

Beam Type	Unit Weight (lb/Ft.)	Quantity	Length (Ft.)	Total Weight (K)
Type 1	816.67	2	38	62.07
Type 1	816.67	2	40	65.33
Type 2	1020.83	3	38	116.37
Type 2	1020.83	3	40	122.50
Type 3	816.67	10	30	245.00
Type 4	816.67	10	30	245.00
Total Beam Weight =				856.28
Joist Slab	Unit Weight (psf)	Area	Total Weight (K)	
4.5" slab	85.42	29184	2492.80	
Column	Unit Weight (lb/Ft.)	Quantity	Length (Ft.)	Total Weight (K)
24x48	1800.00	4	17.167	123.60
24x48 ext.	1200.00	16	17.167	329.61
30x30	937.50	4	17.167	64.38
26x26	704.16	8	18	101.40
Total Structure Weight =				3968.06

Table D.2 – Levels 2 to 5 – Concrete Framing Weight

Beam Type	Unit Weight	Quantity	Length (Ft.)	Total Weight
Type 1	816.67	2	38	62.07
Type 1	816.67	2	40	65.33
Type 2	1020.83	3	38	116.37
Type 2	1020.83	3	40	122.50
Type 3	816.67	10	30	245.00
Type 4	816.67	10	30	245.00
Total Beam Weight =				856.28
Joist Slab	Unit Weight	Area (Ft ²)	Total Weight	
4.5" slab 66"	85.42	29184	2492.80	
Column Type	Unit Weight	Quantity	Length (Ft.)	Total Weight
24x48 corner	1800.00	4	13	93.60
24x48 ext.	1200.00	16	13	249.60
Various	527.34	12	13	82.27
Total Structure Weight =				3774.54

Table D.3 – Level 6 Concrete Framing Weight

Beam Type	Unit Weight (lb/Ft.)	Quantity	Length (Ft.)	Total Weight
Type 1	816.67	2	38	62.07
Type 1	816.67	2	40	65.33
Type 2	1020.83	3	38	116.37
Type 2	1020.83	3	40	122.50
Type 3	816.67	10	30	245.00
Type 4	816.67	10	30	245.00
Total Beam Weight =				856.28
Joist Slab Type	Unit Weight	Area (Ft ²)		Total Weight
4.5" slab 66"	85.42	29184		2492.80
Column Type	Unit Weight	Quantity	Length (Ft.)	Total Weight
24x48 corner	1800.00	4	12.58	90.58
24x48 ext.	1200.00	16	12.58	241.54
20x20 int.	416.67	12	12.58	62.90
Total Structure Weight =				3744.09

Table D.4 – Roof Level Framing Weight

Beam Type	Unit Weight	Quantity	Length (Ft.)	Total Weight
Type 1	597.9	2	38	45.44
Type 1	597.9	2	40	47.83
Type 2	597.9	3	38	68.16
Type 2	597.9	3	40	71.75
Type 3	512.5	10	30	153.75
Type 4	512.5	10	30	153.75
Total Beam				540.69
Joist Slab Type	Unit Weight	Area (Ft ²)		Total Weight
4.5" slab 66"	79.58	29184		2322.46
Column Type	Unit Weight	Quantity	Length (Ft.)	Total Weight
20x20 column	416.67	32	0	0.00
Total				2863.15

Table D.5 – Estimated Building Weight

Level	Load Type	Design psf	Area (Ft ²)	Weight (K)
Level 1	Concrete	--	29184	3968.06
	Ceiling, Misc	5	29184	145.92
	MEP	5	29184	145.92
	Exterior wall	50	12223	611.15
	partitions	10	29184	291.84
	Total floor			5162.89
Level 2-5	Concrete	--	29184	3774.54
	Ceiling, Misc	5	29184	145.92
	MEP	5	29184	145.92
	Exterior wall	50	9256	462.80
	partitions	10	29184	291.84
	Total floor			4821.02
Level 6	Concrete	--	29184	3744.09
	Ceiling, Misc	5	29184	145.92
	MEP	5	29184	145.92
	Exterior wall	50	8957	447.85
	partitions	10	29184	291.84
	Total floor			4775.62
Roof	Concrete	--	29184	2863.15
	Roofing,	8	29184	233.47
	Collateral Load	7	29184	204.29
	Total Roof			3300.91
Upper Roof	Turret framing	10	381	3.81
	Turret exterior	50	1124	56.20
	Tower Framing	10	1513	15.13
	Tower Exterior	50	1348	67.40
	Total Upper			142.54
TOTAL BUILDING WEIGHT =				32666.04

Seismic hand calculations

Seismic Analysis	Final Report	Page 1 of 2
<u>ASCE 7-05 - chapters 11, 12 and 22</u>		
Side class: D	$S_s = 0.15 \Rightarrow F_a = 1.6$ $S_1 = 0.04 \Rightarrow F_v = 2.4$	
	$S_{M3} = F_a S_1 = 0.24$	$S_{M1} = F_v S_1 = 0.096$
<u>Design spectral acceleration parameters</u>		
	$S_{D5} = \frac{2}{3} S_{M3} = 0.16$	$S_{D1} = \frac{2}{3} S_{M1} = 0.064$
AMFRAD	<u>Determination of the Period, T:</u>	
	Lateral Force Resisting System: Ordinary concrete moment frame	
	Per table 17.8-2: $C_e = 0.016$ $h_n = 103 \text{ ft}$ $\alpha = 0.9$	
	$T_a = C_e h_n^\alpha = 0.016 (103)^{0.9} = 1.037 \text{ s}$	$S_{D1} \leq 0.1 \Rightarrow C_u = 1.7$ $C_u T_a = 1.7 (1.037)$ $= 1.76 \text{ s}$
	<u>Design spectral response acceleration:</u>	
	$T_0 = 0.2 \frac{S_{D1}}{S_{D5}} = 0.2 \left(\frac{0.064}{0.160} \right) = .08$	
	$T_S = \frac{S_{D1}}{S_{D5}} = \frac{.064}{.160} = 0.4$	$T_L = 12$ (from Figure 22-15)
	For $T_S < T < T_L \Rightarrow S_a = \frac{S_{D1}}{T} = \frac{0.064}{1.037} = .062$	
	Impedance Factor: $I = 1.0$	Seismic Design Category: A
	$F_x = 0.01 w_x$	
	$R = 3.0$ (ordinary reinforced concrete moment frames)	

Seismic Analysis	Final Report	Page 2 of 2
------------------	--------------	-------------

12.8 - Equivalent Lateral Force Procedure

Building height Estimate: see spreadsheets

Seismic Base shear:

$$V = C_s W \Rightarrow W = 32666 \text{ k} \leftarrow \text{from spreadsheet}$$

$$C_s = \frac{S_{Ds}}{(R/I)} \leq \frac{S_{D1}}{(R/I)} \text{ for } T < T_L$$

$$\frac{S_{Ds}}{(R/I)} = \frac{0.16}{(3/1)} = .0533 > \frac{S_{D1} I}{TR} = \frac{.064(1)}{1.037(3)} = .0206$$

therefore \Rightarrow take $C_s = .0206$ $.0206 > .01 \checkmark \text{ ok}$

$$V = C_s W = .0206 (32666 \text{ k}) = 672.92 \text{ k}$$

Find k through interpolation: $\frac{2.5 - .5}{2 - 1} = \frac{1.037 - .5}{k - 1}$

$$k = 1.269$$

$$C_{vx} = \frac{w_x h_x^k}{\sum_{i=1}^n w_i h_i^k} \qquad F_x = C_{vx} V$$

Appendix E: Computer Model Analysis

Diaphragm mass application

Diaphragm Mass Application	Final Report	Page 1 of 2
----------------------------	--------------	-------------

Floors Sublevel to Story 5

Slab (Joist self weight) = 81.96 psf (accounting for openings)
Super-imposed DL = 20 psf

Length of 24.5 x 32 Beams = $2(42+42+44) + 20(30) = 856 \text{ ft}$

Length of 24.5 x 40 Beams = $2(42+42+44) = 256 \text{ ft}$

Total Beam Weight = $856 \text{ ft} \left(816.67 \frac{\text{lb}}{\text{ft}} \right) + 256 \left(1020.83 \frac{\text{lb}}{\text{ft}} \right)$
 $= 960.40 \text{ k} \Rightarrow \frac{960.40}{128(228)} = 32.91 \text{ psf}$

Total floor system load = $32.91 \text{ psf} + 20 \text{ psf} + 81.96 \text{ psf}$
 $= 134.87 \text{ psf}$ for floors "Sublevel" to "Story 5"

Story 6

Slab/Joist self weight = 79.58 psf (16" pan depth)
Super-imposed DL = 20 psf

Length of 20.5 x 28 Beams = $4(42+42+44) = 512 \text{ ft}$ ($597.92 \frac{\text{lb}}{\text{ft}}$)
 Length of 20.5 x 24 Beams = $20(30) = 600 \text{ ft}$ ($512.5 \frac{\text{lb}}{\text{ft}}$)

Total beam weight = $(512 \text{ ft}) \left(597.92 \frac{\text{lb}}{\text{ft}} \right) + (600 \text{ ft}) \left(512.5 \frac{\text{lb}}{\text{ft}} \right)$
 $= 613635 \text{ lb}$ Load = $\frac{613635}{128(228)} = 21.02 \text{ psf}$

Total floor system load = $21.02 + 79.58 + 20 = 120.6 \text{ psf}$ for "Story 6"

Individual Story loads

Sublevel

Floor system = 134.87 psf

Exterior wall load = $\frac{50 \text{ psf} (2)(128+228)(8.58)}{128(228)} = 10.47 \text{ psf}$

Column load = $150 \text{ psf} \left(\frac{1728}{144} \right) (4)(8.58) + 16 \left(150 \text{ psf} \right) \left(\frac{24 \times 48}{144} \right) (8.58)$
 $+ 4 \left(150 \text{ psf} \right) \left(\frac{30 \times 30}{144} \right) (8.58) + 8 \left(\frac{26 \times 26}{144} \right) (150)(8.58)$
 $= 61776 + 164736 + 32175 + 48334 = \frac{307021}{128(228)} = 10.52 \text{ psf}$

Shell Area Mass = $\frac{134.87 + 10.47 + 10.52}{(1000)(32.2)(123)} = 2.801 \text{ e-6}$

Diaphragm Mass Application

Final Report

Page 2 of 2

Story 1

Floor System = 134.87 (see page 1)

Exterior wall load = $\frac{50 \text{ psf} (2) (128 + 228) (15.08)}{128 (228)} = 18.39 \text{ psf}$

Columns = $\frac{26400 (15.08)}{128 (228)} + \frac{12 (26 \times 26) (150) (15.08)}{128 (228) (144)} = 18.00 \text{ psf}$

Shell Area Mass = $\frac{134.87 + 18.39 + 18}{1000 (32.2) (12^3)} = 3.078 \text{ e-6}$

Stories 2-4

Floor System = 134.87 psf

Exterior wall load = $\frac{50 \text{ psf} (2) (128 + 228) (13.00)}{128 (228)} = 15.86 \text{ psf}$

Columns = $\frac{26400 (13)}{128 (228)} + \frac{12 (27.53 \times 27.53) (150) (13)}{128 (228) (144)} = 14.54 \text{ psf}$

Shell Area Mass = $\frac{134.87 + 15.86 + 14.54}{1000 (32.2) (12^3)} = 2.97 \text{ e-6}$

Story 5

Floor system = 134.87 psf

Exterior wall load = $\frac{50 \text{ psf} (2) (128 + 228) (12.79)}{128 (228)} = 15.60 \text{ psf}$

Columns = $\frac{26400 (12.79)}{128 (228)} + \frac{12 (400) (150) (12.79)}{128 (228) (144)} = 13.76 \text{ psf}$

Shell Area Mass = $\frac{134.87 + 15.60 + 13.76}{1000 (32.2) (12^3)} = 2.952 \text{ e-6}$

Story 6

Floor system = 120.6 psf

Exterior wall load = $\frac{50 \text{ psf} (2) (128 + 228) (6.29)}{128 (228)} = 7.67 \text{ psf}$

Columns = $\frac{26400 (6.29)}{128 (228)} + \frac{12 (400) (150) (6.29)}{128 (228) (144)} = 6.77 \text{ psf}$

Shell Area Mass = $\frac{120.6 + 7.67 + 6.77}{1000 (32.2) (12^3)} = 2.427 \text{ e-6}$

416.67
876.04

20-20"
12-20"

AMPAD

416.67
20x32

ETABS model outputs

TABLE D.1 – Centers of Mass and Rigidity

Story	Diaphragm	MassX	MassY	XCM	YCM	CumMassX	CumMassY	XCCM	YCCM	XCR	YCR
STORY6	D1	10.1995	10.1995	1368	768	10.1995	10.1995	1368	768	1347.167	777.482
STORY5	D1	12.4058	12.4058	1368	768	22.6052	22.6052	1368	768	1347.748	777.484
STORY4	D1	12.4814	12.4814	1368	768	35.0866	35.0866	1368	768	1349.227	776.677
STORY3	D1	12.4814	12.4814	1368	768	47.5681	47.5681	1368	768	1351.294	775.368
STORY2	D1	12.4814	12.4814	1368	768	60.0495	60.0495	1368	768	1354.145	773.573
STORY1	D1	12.9353	12.9353	1368	768	72.9847	72.9847	1368	768	1357.659	771.237
SUBLEVEL	D1	11.7712	11.7712	1368	768	84.7559	84.7559	1368	768		

TABLE D.2 - Load Combinations Used

Combo	Equation
1	1.4D
2	1.2D + 1.6L
3	1.2D + L
4	1.2D + 0.8WX
5	1.2D + 0.8WY
6	1.2D + 1.6WY + L
7	1.2D + 1.6WX + L
8	1.2D + 1.0 EX + L
9	1.2D + 1.0 EY + L
10	0.9D + 1.6WX
11	0.9D + 1.6WY
12	0.9D + 1.0 EX
13	0.9D + 1.0 EY

TABLE D.3 – Level 1 ETABS Deflection Outputs

Load	X-axis	Y-axis	$h_x/400$ (in)	$0.02 h_{sx}$	Acceptabl
COMB1	0.0007	0.0004	0.51	4.12	Yes
COMB2	0.0006	0.0004	0.51	4.12	Yes
COMB3	0.0006	0.0004	0.51	4.12	Yes
COMB4	0.0412	0.0004	0.51	4.12	Yes
COMB5	0.0006	0.0952	0.51	4.12	Yes
COMB6	0.0007	0.1899	0.51	4.12	Yes
COMB7	0.0817	0.0004	0.51	4.12	Yes
COMB8	0.3188	0.0006	0.51	4.12	Yes
COMB9	0.0008	0.4239	0.51	4.12	Yes
COMB10	0.0816	0.0003	0.51	4.12	Yes
COMB11	0.0005	0.1898	0.51	4.12	Yes
COMB12	0.3187	0.0005	0.51	4.12	Yes
COMB13	0.0007	0.4238	0.51	4.12	Yes

TABLE D.4 – Level 2 ETABS Deflection Outputs

Load	X-axis	Y-axis	$h_x/400$ (in)	$0.02 h_{sx}$	Acceptabl
COMB1	0.0018	0.0014	0.905	7.24	Yes
COMB2	0.0015	0.0012	0.905	7.24	Yes
COMB3	0.0015	0.0012	0.905	7.24	Yes
COMB4	0.0993	0.0013	0.905	7.24	Yes
COMB5	0.0017	0.2301	0.905	7.24	Yes
COMB6	0.0018	0.459	0.905	7.24	Yes
COMB7	0.1971	0.0014	0.905	7.24	Yes
COMB8	0.7958	0.0019	0.905	7.24	Yes
COMB9	0.0022	1.0611	0.905	7.24	Yes
COMB10	0.1967	0.0011	0.905	7.24	Yes
COMB11	0.0014	0.4587	0.905	7.24	Yes
COMB12	0.7954	0.0016	0.905	7.24	Yes
COMB13	0.0018	1.0608	0.905	7.24	Yes

TABLE D.5 – Level 3 ETABS Deflection Outputs

Load	X-axis	Y-axis	$h_x/400$ (in)	$0.02 h_{sx}$	Acceptabl
COMB1	0.0032	0.0025	1.30	10.36	Yes
COMB2	0.0027	0.0021	1.30	10.36	Yes
COMB3	0.0027	0.0021	1.30	10.36	Yes
COMB4	0.1614	0.0023	1.30	10.36	Yes
COMB5	0.003	0.3742	1.30	10.36	Yes
COMB6	0.0032	0.7462	1.30	10.36	Yes
COMB7	0.32	0.0024	1.30	10.36	Yes
COMB8	1.3375	0.0034	1.30	10.36	Yes
COMB9	0.004	1.7868	1.30	10.36	Yes
COMB10	0.3194	0.0019	1.30	10.36	Yes
COMB11	0.0025	0.7457	1.30	10.36	Yes
COMB12	1.3369	0.0029	1.30	10.36	Yes
COMB13	0.0033	1.7862	1.30	10.36	Yes

TABLE D.6 – Level 4 ETABS Deflection Outputs

Load	X-axis	Y-axis	$h_x/400$ (in)	$0.02 h_{sx}$	Acceptabl
COMB1	0.0045	0.0038	1.685	13.48	Yes
COMB2	0.0038	0.0033	1.685	13.48	Yes
COMB3	0.0038	0.0033	1.685	13.48	Yes
COMB4	0.2176	0.0035	1.685	13.48	Yes
COMB5	0.0042	0.5045	1.685	13.48	Yes
COMB6	0.0046	1.0058	1.685	13.48	Yes
COMB7	0.4313	0.0037	1.685	13.48	Yes
COMB8	1.8601	0.0052	1.685	13.48	Yes
COMB9	0.0058	2.4872	1.685	13.48	Yes
COMB10	0.4303	0.0029	1.685	13.48	Yes
COMB11	0.0036	1.0049	1.685	13.48	Yes
COMB12	1.8592	0.0044	1.685	13.48	Yes
COMB13	0.0048	2.4864	1.685	13.48	Yes

TABLE D.7 – Level 5 ETABS Deflection Outputs

Load	X-axis	Y-axis	$h_x/400$ (in)	$0.02 h_{sx}$	Acceptabl
COMB1	0.0056	0.0049	2.075	16.6	Yes
COMB2	0.0048	0.0042	2.075	16.6	Yes
COMB3	0.0048	0.0042	2.075	16.6	Yes
COMB4	0.2625	0.0045	2.075	16.6	Yes
COMB5	0.0053	0.6081	2.075	16.6	Yes
COMB6	0.0058	1.212	2.075	16.6	Yes
COMB7	0.5201	0.0047	2.075	16.6	Yes
COMB8	2.3026	0.0067	2.075	16.6	Yes
COMB9	0.0073	3.0796	2.075	16.6	Yes
COMB10	0.5189	0.0037	2.075	16.6	Yes
COMB11	0.0046	1.2109	2.075	16.6	Yes
COMB12	2.3014	0.0057	2.075	16.6	Yes
COMB13	0.0061	3.0786	2.075	16.6	Yes

TABLE D.8 – Level 6 ETABS Deflection Outputs

Load	X-axis	Y-axis	$h_x/400$ (in)	$0.02 h_{sx}$	Acceptabl
COMB1	0.0063	0.0058	2.452	19.62	Yes
COMB2	0.0054	0.005	2.452	19.62	Yes
COMB3	0.0054	0.005	2.452	19.62	Yes
COMB4	0.295	0.0053	2.452	19.62	Yes
COMB5	0.006	0.6838	2.452	19.62	Yes
COMB6	0.0066	1.3626	2.452	19.62	Yes
COMB7	0.5846	0.0056	2.452	19.62	Yes
COMB8	2.6378	0.008	2.452	19.62	Yes
COMB9	0.0084	3.5312	2.452	19.62	Yes
COMB10	0.5833	0.0044	2.452	19.62	Yes
COMB11	0.0052	1.3613	2.452	19.62	Yes
COMB12	2.6365	0.0067	2.452	19.62	Yes
COMB13	0.0071	3.53	2.452	19.62	Yes

Appendix F: Foundation & Overturning Calculations

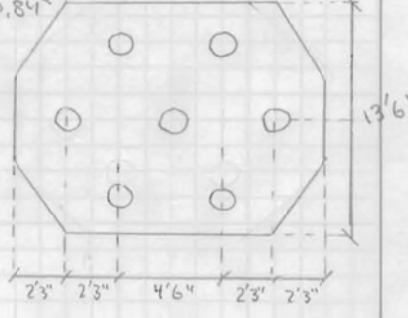
Foundation Bearing and overturning check	Final Report	Page 1 of 2
<p>Typical 18" dia. Auger cast pile: Bearing = 290 k</p>		
<p>Typical axial load at foundation level:</p>		
<p>Max axial load supported by 1st level column = 1540.17 k (see column grid sheet)</p>		
<p>Additional axial load:</p>		
<p>column self weights: Level 1: $\frac{(206k)(30m)(30.4)(150pcf)}{1728} = 16093.75^{lb}$</p>		
<p>Sublevel: $\frac{(126)(30)(30)(150pcf)}{1728} = 9843.75^{lb}$</p>		
<p>$A_{FT} = 43'(30') = 1290 \text{ ft}^2$ Floor LL = 100 psf S.D.L = 70 psf Slab/Joist SW = 85.41 psf</p>		
<p>Deck loads: $P_{DL} \text{ of slab/joist} = 2(1290)(85.41) = 210.35 \text{ k}$</p>		
<p>$P_{DL} \text{ column SW} = \frac{9843.75 + 16093.75}{1000} = 25.94$</p>		
<p>Live load: $P_{DL} \text{ joist} = 246.29 \text{ k}$</p>		
<p>$LL_{red} = (.25 + \frac{15}{\sqrt{k_{11} A_T}}) = (.25 + \frac{15}{\sqrt{14(2)(1290)}}) = .397 < .4 \Rightarrow \text{use } 0.4$</p>		
<p>$P_L = \frac{1290(2)(100)}{1000} = 258 \text{ k}$ $1.2DL + 1.6LL$ $= 1.2(246.29) + 1.6(.4)(258) = 460.67 \text{ k}$</p>		
<p>Total load = $1540.17 \text{ k} + 460.67 \text{ k} = 2000.84 \text{ k}$</p>		
<p>Pile Design</p>		
<p>$\frac{2000.84 \text{ k}}{290 \text{ k/pile}} = 6.899 \Rightarrow \text{use } 7 \text{ piles}$</p>		
		

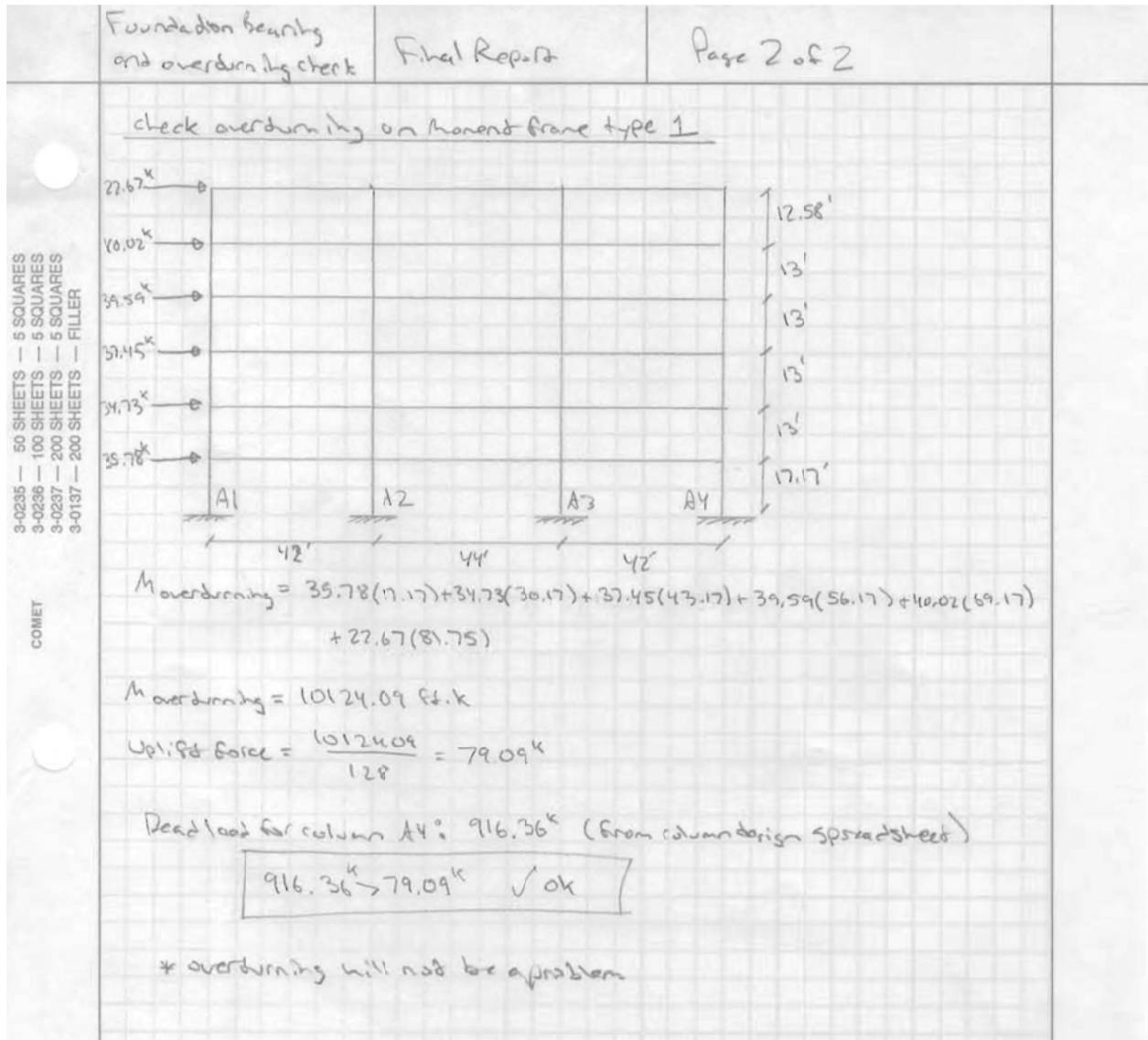

Appendix G: Cost and schedule analysis

Steel Takeoffs

Cost Estimate										
Existing Structural System										
Columns										
Size	PSF	Quantity	Unit	Bare Material	Bare Labor	Bare Equipment	Bare Total	Total O&P	Daily Output (L.F./D)	Days
W14X120	120	7?	L.F.	\$ 10,012.32	\$ 223.92	\$ 136.08	\$ 10,372.32	\$ 11,575.51		
W14x132	132	7?	L.F.	\$ 11,030.72	\$ 223.92	\$ 136.08	\$ 11,390.72	\$ 12,774.70		
W14X145	145	145.32	L.F.	\$ 24,456.31	\$ 475.20	\$ 289.19	\$ 25,220.69	\$ 28,285.01		
W14X99	99	508.32	L.F.	\$ 58,407.68	\$ 1,545.29	\$ 935.31	\$ 60,888.28	\$ 68,286.20		
W14X159	159	3?	L.F.	\$ 6,643.50	\$ 117.72	\$ 71.64	\$ 6,832.86	\$ 7,663.06		
W14X311	311	144	L.F.	\$ 51,978.10	\$ 470.88	\$ 286.56	\$ 52,735.54	\$ 59,142.91		
W14X211	211	257.28	L.F.	\$ 63,006.60	\$ 841.31	\$ 511.99	\$ 64,359.89	\$ 72,179.62		
W14X68	68	204.5	L.F.	\$ 16,455.55	\$ 633.84	\$ 383.64	\$ 17,473.03	\$ 19,534.85		
W14X74	74	275.6	L.F.	\$ 2,375.64	\$ 65.83	\$ 43.98	\$ 2,485.45	\$ 2,886.60		
W14X53	53	55.32	L.F.	\$ 3,402.95	\$ 125.58	\$ 84.09	\$ 3,612.61	\$ 4,051.55		
W14X61	61	165.96	L.F.	\$ 11,749.81	\$ 394.98	\$ 263.88	\$ 12,408.67	\$ 13,916.32		
W14X90	90	131.3	L.F.	\$ 14,446.49	\$ 329.15	\$ 219.90	\$ 14,995.54	\$ 16,817.49		
W14X48	48	276	L.F.	\$ 15,376.16	\$ 626.52	\$ 419.52	\$ 16,422.20	\$ 18,417.50		
W14X109	109	276	L.F.	\$ 34,916.69	\$ 673.44	\$ 449.88	\$ 36,040.01	\$ 40,418.88		
W14X82	82	262.62	L.F.	\$ 27,575.10	\$ 625.04	\$ 417.57	\$ 28,617.70	\$ 32,002.87		
		2641.28		\$ 241,990.78	\$ 4,532.07	\$ 2,750.48	\$ 246,273.34	\$ 279,441.85	1000	2.65
Floor Members										
level 1										
Size	PSF	Quantity	Unit	Bare Material	Bare Labor	Bare Equipment	Bare Total	Total O&P	Daily Output (L.F./D)	Days
W18X40	40	151.2	L.F.	\$ 70,323.12	\$ 6,804.00	\$ 3,129.84	\$ 80,256.96	\$ 91,959.84	900	1.68
W27X94	94	84	L.F.	\$ 9,183.76	\$ 305.76	\$ 139.44	\$ 9,628.96	\$ 10,744.44	1175	0.07
W24X62	62	126	L.F.	\$ 9,063.17	\$ 490.14	\$ 224.28	\$ 9,777.59	\$ 12,021.66	1100	0.11
W24X55	55	129	L.F.	\$ 8,226.37	\$ 501.81	\$ 229.62	\$ 8,957.80	\$ 10,143.27	1100	0.12
W24X76	76	84	L.F.	\$ 7,411.32	\$ 326.76	\$ 149.52	\$ 7,887.60	\$ 8,860.32	1100	0.08
W18X35	35	99	L.F.	\$ 4,035.24	\$ 445.50	\$ 204.93	\$ 4,685.67	\$ 5,403.42	900	0.11
W21X44	44	690	L.F.	\$ 35,072.69	\$ 2,801.40	\$ 1,283.40	\$ 38,157.49	\$ 44,919.00	1025	0.67
W27X94	94	118	L.F.	\$ 12,900.94	\$ 429.52	\$ 195.88	\$ 13,526.34	\$ 15,093.38	1175	0.10
W30X99	99	144	L.F.	\$ 18,873.12	\$ 590.40	\$ 270.60	\$ 19,734.12	\$ 22,066.20	1175	0.14
W24X68	68	9?	L.F.	\$ 7,595.52	\$ 373.44	\$ 170.88	\$ 8,139.84	\$ 9,159.36	1100	0.09
W12X19	19	4?	L.F.	\$ 1,057.92	\$ 162.72	\$ 99.36	\$ 1,320.00	\$ 1,374.24	700	0.07
W27X146	146	120	L.F.	\$ 20,368.80	\$ 450.00	\$ 226.80	\$ 21,045.60	\$ 23,416.80	1175	0.10
W27X84	84	6?	L.F.	\$ 5,869.20	\$ 218.40	\$ 99.60	\$ 6,187.20	\$ 6,926.40	1175	0.05
W30X90	90	3?	L.F.	\$ 3,138.54	\$ 108.00	\$ 49.50	\$ 3,296.04	\$ 4,036.50	1175	0.03
W30X116	116	8?	L.F.	\$ 10,740.80	\$ 298.40	\$ 136.00	\$ 11,175.20	\$ 12,474.40	1175	0.07
		3440	L.F.	\$ 223,860.51	\$ 14,306.25	\$ 6,609.65	\$ 244,776.41	\$ 278,599.23	950	3.62
Floor Members										
levels 2-6										
Size	PSF	Quantity	Unit	Bare Material	Bare Labor	Bare Equipment	Bare Total	Total O&P	Daily Output (L.F./D)	Days
W18X40	40	152.1	L.F.	\$ 70,741.71	\$ 6,844.50	\$ 3,148.47	\$ 80,734.68	\$ 92,507.22	900	1.69
W18X50	50	4?	L.F.	\$ 2,320.80	\$ 189.20	\$ 86.80	\$ 2,596.80	\$ 2,970.80	900	0.04
W27X94	94	84	L.F.	\$ 9,183.76	\$ 305.76	\$ 139.44	\$ 9,628.96	\$ 10,744.44	1175	0.07
W24X62	62	126	L.F.	\$ 9,063.17	\$ 490.14	\$ 224.28	\$ 9,777.59	\$ 12,021.66	1100	0.11
W24X55	55	240	L.F.	\$ 15,364.87	\$ 933.60	\$ 427.20	\$ 16,665.67	\$ 18,871.20	1100	0.22
W24X76	76	84	L.F.	\$ 7,411.32	\$ 326.76	\$ 149.52	\$ 7,887.60	\$ 8,860.32	1100	0.08
W18X35	35	108	L.F.	\$ 4,402.08	\$ 486.00	\$ 223.56	\$ 5,111.64	\$ 5,894.64	900	0.12
W21X50	50	7?	L.F.	\$ 4,235.46	\$ 296.38	\$ 135.78	\$ 4,667.62	\$ 5,312.21	1025	0.07
W21X44	44	82?	L.F.	\$ 41,782.25	\$ 3,337.32	\$ 1,528.92	\$ 46,648.49	\$ 53,512.20	1025	0.80
W27X94	94	84	L.F.	\$ 9,183.72	\$ 305.76	\$ 139.44	\$ 9,628.92	\$ 10,744.44	1175	0.07
W30X99	99	7?	L.F.	\$ 8,746.08	\$ 273.60	\$ 125.40	\$ 9,145.08	\$ 10,225.80	1175	0.06
W24X68	68	2?	L.F.	\$ 16,911.67	\$ 832.46	\$ 380.92	\$ 18,145.05	\$ 20,417.74	1100	0.19
W16X31	31	3?	L.F.	\$ 1,078.80	\$ 99.60	\$ 60.60	\$ 1,239.00	\$ 1,428.60	850	0.04
W12X14	14	7?	L.F.	\$ 1,451.39	\$ 265.10	\$ 161.87	\$ 1,878.36	\$ 2,238.87	700	0.11
W12X19	19	3?	L.F.	\$ 749.36	\$ 115.26	\$ 70.38	\$ 935.00	\$ 973.42	700	0.05
W27X146	146	120	L.F.	\$ 20,368.80	\$ 450.00	\$ 226.80	\$ 21,045.60	\$ 23,416.80	1175	0.10
W27X84	84	120	L.F.	\$ 11,738.40	\$ 436.80	\$ 199.20	\$ 12,374.40	\$ 13,852.80	1175	0.10
W30X90	90	1.8	L.F.	\$ 12,344.94	\$ 424.80	\$ 194.70	\$ 12,964.44	\$ 15,876.90	1175	0.10
W30X116	116	8?	L.F.	\$ 10,740.80	\$ 298.40	\$ 136.00	\$ 11,175.20	\$ 12,474.40	1175	0.07
		4052.2		\$ 257,779.39	\$ 16,711.44	\$ 7,759.28	\$ 282,250.12	\$ 322,344.46	950	4.27

Concrete Takeoffs

Redesigned Structural System										
Concrete Formwork										
Beams										
Levels 1-4										
Size	Quantity	Unit	Bare Material	Bare Labor	Bare Equipment	Bare Total	Total O&P	Daily Output (S.F./D)	Days	
Ext. 24" wide 4 use (beams)	1454	SFCA	\$ 1,219.52	\$ 7,997.00	\$ -	\$ 9,276.52	\$ 13,842.08	325.00	4.47	
Int. 24" wide 4 use (beams)	16966	SFCA	\$ 15,059.74	\$ 76,516.66	\$ -	\$ 91,616.40	\$ 135,388.68	395.00	42.95	
Int. 12" (bot) 4 use (beams)	3258	SFCA	\$ 3,746.70	\$ 18,733.50	\$ -	\$ 22,480.20	\$ 33,264.18	310.00	10.51	
Int. 30" (bot) 4 use (beams)	3083	SFCA	\$ 4,131.22	\$ 18,960.45	\$ -	\$ 23,091.67	\$ 34,005.49	290.00	10.63	
Levels 5-6										
Ext. 24" wide 2 use (beams)	1454	SFCA	\$ 2,210.08	\$ 8,942.10	\$ -	\$ 11,152.18	\$ 16,313.88	325.00	4.47	
Int. 24" wide 2 use (beams)	16966	SFCA	\$ 26,297.30	\$ 82,794.08	\$ -	\$ 109,091.38	\$ 157,783.80	365.00	46.48	
Int. 12" (bot) 2 use (beams)	3258	SFCA	\$ 6,052.46	\$ 21,177.00	\$ -	\$ 27,269.46	\$ 39,617.28	275.00	11.85	
Int. 30" (bot) 2 use (beams)	3083	SFCA	\$ 7,111.73	\$ 20,810.25	\$ -	\$ 27,931.98	\$ 40,048.17	265.00	11.63	
Roof Level										
Ext. 24" wide 1 use (beams)	1217	SFCA	\$ 3,298.07	\$ 8,214.75	\$ -	\$ 11,512.82	\$ 16,344.31	265.00	4.59	
Int 18" wide 1 use (beams)	13242	SFCA	\$ 36,547.92	\$ 73,493.10	\$ -	\$ 110,041.02	\$ 154,666.55	320.00	41.38	
Int. 12" (bot) 1 use (beams)	3258	SFCA	\$ 11,500.74	\$ 25,738.20	\$ -	\$ 37,238.94	\$ 52,877.34	225.00	14.48	
Int. 24" (bot) 1 use (beams)	2395	SFCA	\$ 6,610.20	\$ 13,292.25	\$ -	\$ 19,902.45	\$ 27,973.60	320.00	7.48	
Columns										
Sublevel										
24" x 48" columns (1 use)	3296	SFCA	\$ 6,427.20	\$ 19,116.80	\$ -	\$ 25,544.00	\$ 36,750.40	200.00	16.48	
24" x 24" columns(1 use)	1099	SFCA	\$ 2,901.36	\$ 6,703.90	\$ -	\$ 9,605.26	\$ 13,583.64	190.00	5.78	
30" x 30" columns(1 use)	687	SFCA	\$ 1,339.65	\$ 3,984.60	\$ -	\$ 5,324.25	\$ 7,660.05	200.00	3.44	
26" x 26" columns(1 use)	1190	SFCA	\$ 3,141.60	\$ 7,259.00	\$ -	\$ 10,400.60	\$ 14,708.40	190.00	6.26	
Levels 1-4										
24" x 48" columns(4 use)	2496	SFCA	\$ 1,572.48	\$ 11,556.48	\$ -	\$ 13,128.96	\$ 19,718.40	250.00	9.98	
24" x 24" columns(4 use)	2080	SFCA	\$ 1,788.80	\$ 10,108.80	\$ -	\$ 11,897.60	\$ 17,680.00	238.00	8.74	
Level 5										
24" x 48" columns(1 use)	2416	SFCA	\$ 4,711.20	\$ 14,012.80	\$ -	\$ 18,724.00	\$ 26,938.40	200.00	12.08	
24" x 24" columns(1 use)	805	SFCA	\$ 2,115.20	\$ 4,910.50	\$ -	\$ 7,035.70	\$ 9,949.80	190.00	4.24	
20" x 20" columns(1 use)	1007	SFCA	\$ 2,497.36	\$ 6,223.26	\$ -	\$ 8,720.62	\$ 12,426.38	185.00	5.44	
Concrete Placement										
Levels 1										
Size/type	Quantity	Unit	Bare Material	Bare Labor	Bare Equipment	Bare Total	Total O&P	Daily Output (S.F./D)	Days	
Slab/Joists/Girders	715.74	C.Y.	\$ 75,868.44	\$ 13,563.27	\$ 5,081.75	\$ 94,513.47	\$ 110,259.75	115	6.22	
Columns	139.61	C.Y.	\$ 14,798.66	\$ 2,610.71	\$ 977.27	\$ 18,386.64	\$ 21,458.06	116	1.20	
Level 2-5										
Slab/Joists/Girders	715.74	C.Y.	\$ 75,868.44	\$ 13,563.27	\$ 5,081.75	\$ 94,513.47	\$ 110,259.75	115	6.22	
Columns	105.77	C.Y.	\$ 11,211.62	\$ 1,977.90	\$ 740.39	\$ 13,929.91	\$ 16,256.85	116	0.91	
Level 6										
Slab/Joists/Girders	715.74	C.Y.	\$ 75,868.44	\$ 13,563.27	\$ 5,081.75	\$ 94,513.47	\$ 110,259.75	115	6.22	
Columns	97.53	C.Y.	\$ 10,338.18	\$ 2,238.31	\$ 824.13	\$ 13,400.62	\$ 15,731.59	92	1.06	
Reinforcing Steel										
Level 1										
Size/type	Quantity	Unit	Bare Material	Bare Labor	Bare Equipment	Bare Total	Total O&P	Daily Output (S.F./D)	Days	
Beams/Girders #8 to #18	74.676	Ton	\$ 69,812.06	\$ 38,084.76	\$ -	\$ 107,906.82	\$ 138,897.36	2.7	27.6578	
Columns #8 to #18	11.159	Ton	\$ 10,433.67	\$ 6,695.40	\$ -	\$ 17,129.07	\$ 22,373.80	2.3	4.85174	
Level 2										
Beams/Girders #8 to #18	74.676	Ton	\$ 69,812.06	\$ 38,084.76	\$ -	\$ 107,906.82	\$ 138,897.36	2.7	27.6578	
Columns #8 to #18	8.133	Ton	\$ 7,604.36	\$ 4,879.80	\$ -	\$ 12,484.16	\$ 16,306.67	2.3	3.53609	
Level 3										
Beams/Girders #8 to #18	74.676	Ton	\$ 69,812.06	\$ 38,084.76	\$ -	\$ 107,906.82	\$ 138,897.36	2.7	27.6578	
Columns #8 to #18	8.028	Ton	\$ 7,506.18	\$ 4,816.80	\$ -	\$ 12,322.98	\$ 16,096.14	2.3	3.49043	
Level 4										
Beams/Girders #8 to #18	74.676	Ton	\$ 69,812.06	\$ 38,084.76	\$ -	\$ 107,906.82	\$ 138,897.36	2.7	27.6578	
Columns #8 to #18	7.924	Ton	\$ 7,408.94	\$ 4,754.40	\$ -	\$ 12,163.34	\$ 15,887.62	2.3	3.44522	
Level 5										
Beams/Girders #8 to #18	74.676	Ton	\$ 69,812.06	\$ 38,084.76	\$ -	\$ 107,906.82	\$ 138,897.36	2.7	27.6578	
Columns #8 to #18	7.924	Ton	\$ 7,408.94	\$ 4,754.40	\$ -	\$ 12,163.34	\$ 15,887.62	2.3	3.44522	
Level 6										
Beams/Girders #8 to #18	74.676	Ton	\$ 69,812.06	\$ 38,084.76	\$ -	\$ 107,906.82	\$ 138,897.36	2.7	27.6578	
Columns #8 to #18	7.668	Ton	\$ 7,169.58	\$ 4,600.80	\$ -	\$ 11,770.38	\$ 15,374.34	2.3	3.33391	

Appendix H: Acoustic Analysis

	Acoustics Breadth	Final Report	Page 1 of 1
<p>3-0235 — 50 SHEETS — 5 SQUARES 3-0236 — 100 SHEETS — 5 SQUARES 3-0237 — 200 SHEETS — 5 SQUARES 3-0137 — 200 SHEETS — FILLER</p> <p>COMET</p>	<p><u>Noise Reduction for Level 1 floor above Parking level</u></p> <p>Subway drain = 95 dB (as measured from platform)</p> <p>"Rough" soil NRC = 0.45</p> <p>5.5" Concrete S.O.F. NRC = 0.02</p> <p>Surface Area, S that is directly above subway line = 30' x 128' = 3840 ft²</p> <p>S = 3840 for both soil and concrete</p> <p>Absorption due to concrete = $\Sigma S\alpha = 3840(.02) = 76.8$ Sabins</p> <p>Absorption of two layers conc. + soil =</p> <p>$= \Sigma S\alpha = 3840(.02 + .02 + .45) = 1881.6$ Sabins</p> <p>$NR = 10 \log \frac{a_2}{a_1} = 10 \log \frac{1881.6}{76.8} = 10 \log 24.5 = 13.89 \approx 14$ dBA</p> <p>TL = 47 dBA (concrete) + 14 dBA (soil) = 61 dBA</p> <p>Subway noise level in parking garage = 95 - 61 = 34 dBA</p> <p>Level 2 TL = 51.7 - 32 = 19.7 dBA (at 125 Hz)</p> <p><u>Roof structure comparison</u></p> <p>20 gage galvanized roof deck: TL = 24 dBA</p> <p>4.5" concrete slab roof system: TL = 47 dBA</p> <p>} = Additional 23 dB reduction</p> <p>Subway drain on platform = 95 dBA</p> <p>Passenger car at 50 ft = 71 dBA</p>		